

sistemi e soluzioni di arredo

furnishing systems and solutions



GIBAM

 **composit**

 **M18**





M18

montanti / uprights

basi / bases

schienali / back panels

ripiani / shelves

mobiletti di base / base cabinets

vetrine / glass-cases

angoli e curve / corners and curves

testate di gondola / gondola heads

comunicazione e luce / communication and light

minirack / minirack



M18

new perspective

PHARMADE SOLUTION

Voltaren

Voltaren



montanti
uprights

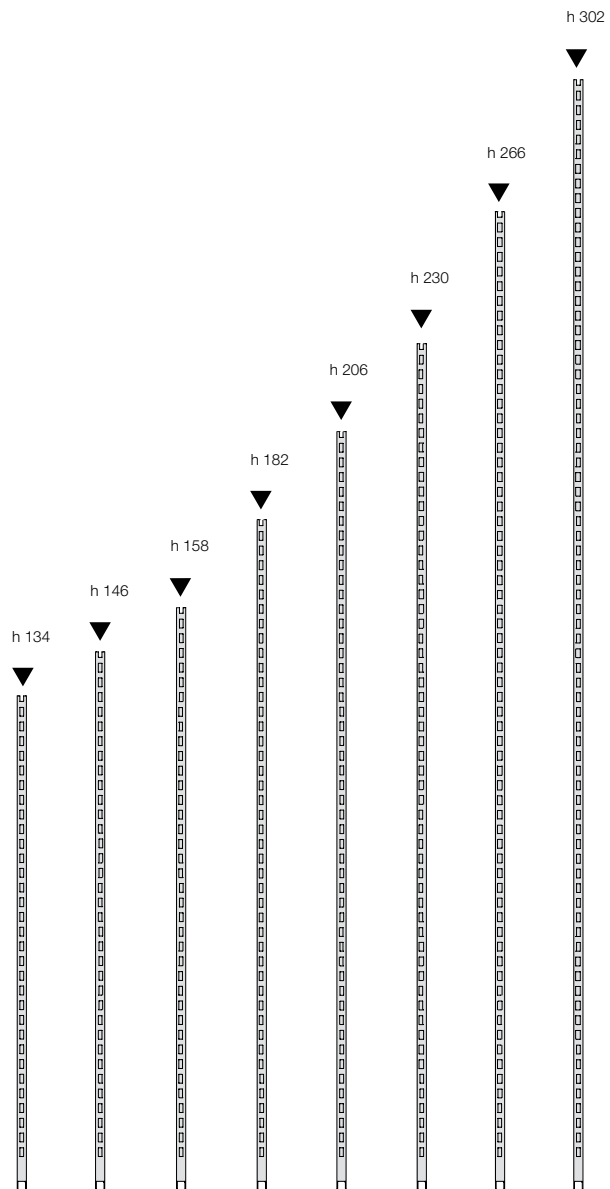



PHARMADE SOLUTION

... stile e design nell'arred

GIBAM SHOPS

Pharmade Solution è un prodotto GIBAM
... www.pharmadesolution.it - far

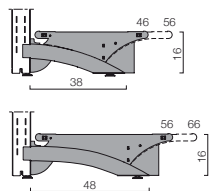

base tubolare **con ripiani in metallo**
tubular base **with metal shelves**

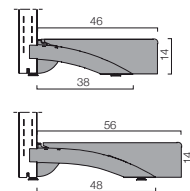

base tubolare **con ripiano pedana**
tubular base **with lower platform**

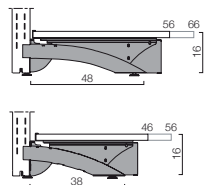

base tubolare **con ripiani in legno**
tubular base **with wooden shelves**

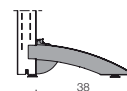

base tubolare **con carter**
tubular base **with carter**

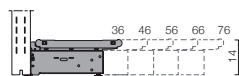

base scatolata **per ripiani in metallo**
box-type base **for metal shelves**

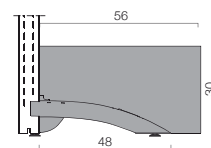

base tubolare **con pedana luminosa**
tubular base **with lit platform**

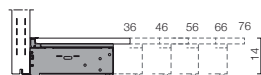

base scatolata **per ripiani in legno**
box-type base **for wooden shelves**

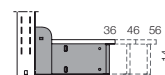

base strutturale **per ripiani in legno**
structural base **for wooden shelves**



schienali **lisci**
smooth back panels

schienali in aggetto **“zona disting”**
jutting back panels **“focus area”**

schienali **a pannelli**
panelled back panels

passi
pitches

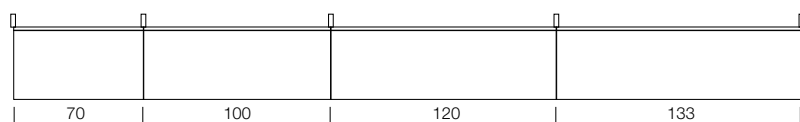

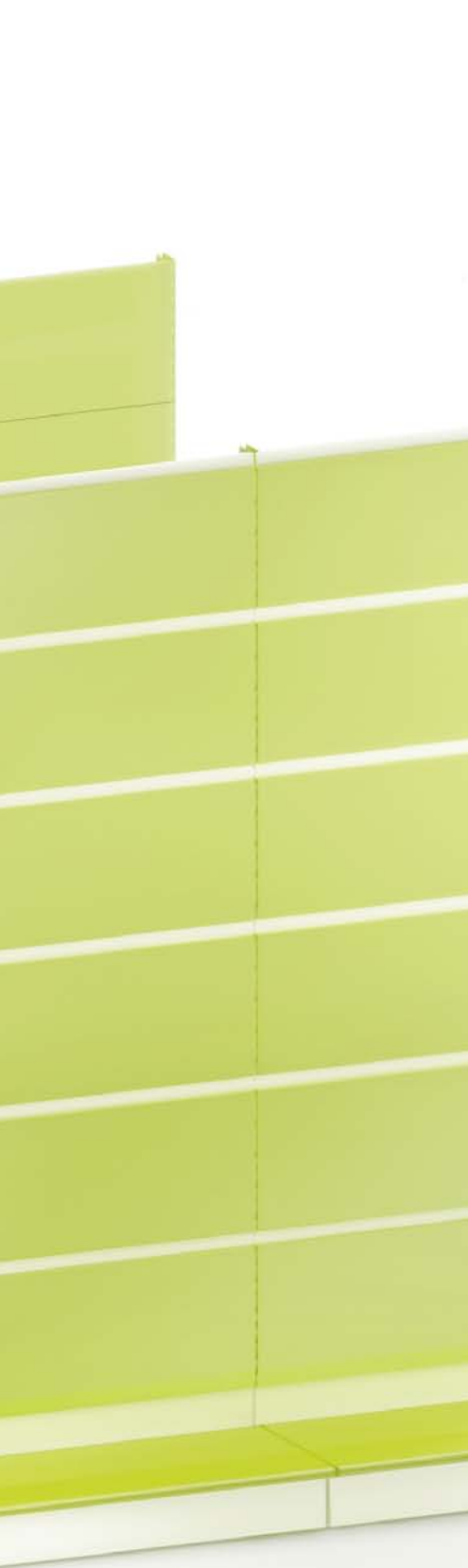

metallo
metal

doghe in metallo
metal slats

forati in metallo
perforated metal

legno melaminico
melamine-coated wood

doghe in legno MDF
MDF wooden slats

luminosi in plexiglass opalino
lit in matt acrylic

luminosi con immagine
lit with image

legno melaminico lucido
gloss melamine-coated wood

legno verniciati testurizzati
textured painted wood

legno verniciati laccati
lacquered painted wood

legno laminati a scelta
selection of laminated wood

schienali
back panels





mobiletti raccordo **ripiani in metallo**
su base scatolata

metal shelves connecting cabinets
on box-type base

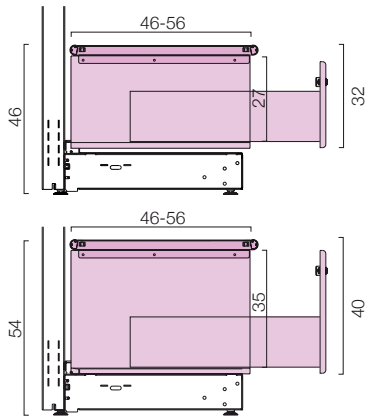

mobiletti raccordo **ripiani in legno**
su base scatolata

wooden shelves connecting cabinets
on box-type base

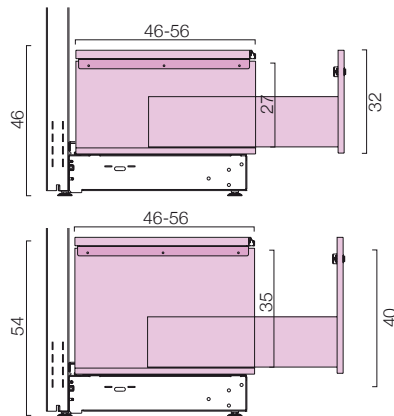

mobiletti raccordo **ripiani in metallo**
su base tubolare

metal shelves connecting cabinets
on tubular base

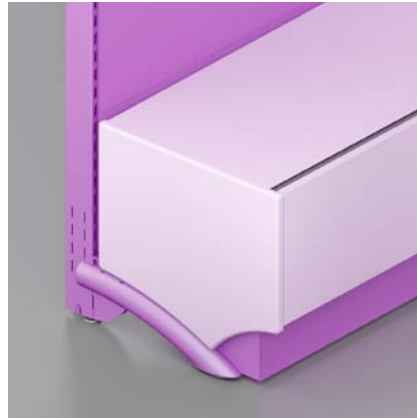
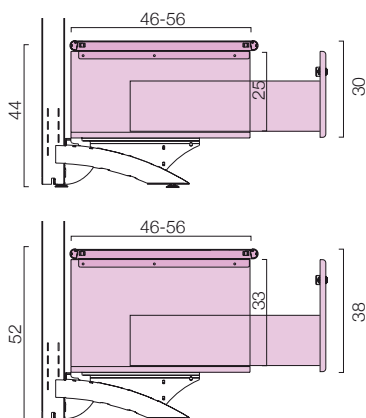

mobiletti raccordo **ripiani in legno**
su base tubolare

wooden shelves connecting cabinets
on tubular base

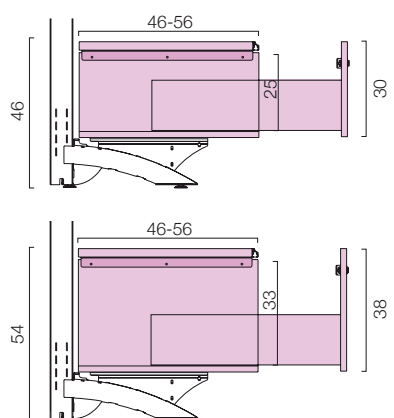

ripiani su mensole serie PZ

shelves on brackets PZ series

ripiano in legno wooden shelf

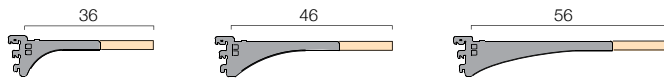

ripiano con canalino
porta accessori
shelf with
accessories groove



portaprezzo
price holder



spondina anticaduta
protective front



spondina e divisori
protective sides
and dividers

ripiano in vetro glass shelf

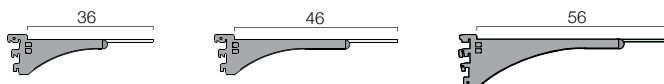
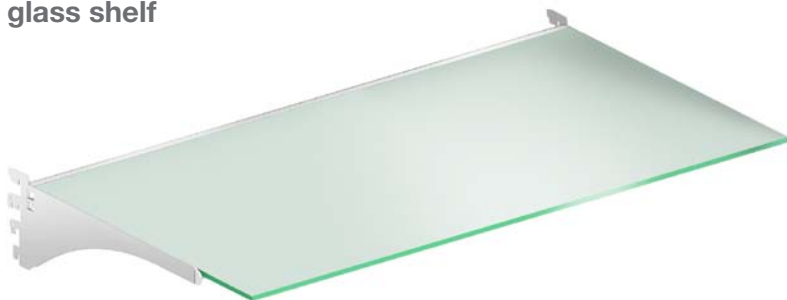

ripiano con canalino
porta accessori
shelf with
accessories groove



portaprezzo
price holder



spondina anticaduta
protective side



spondina e divisori
protective sides
and dividers

ripiano in vetro luminoso lighted glass shelf

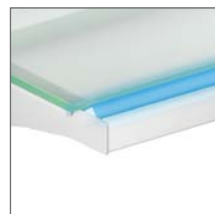
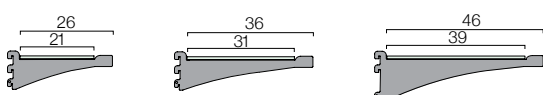

schermo luminoso
colorato anticaduta
tinted and lit
protective front

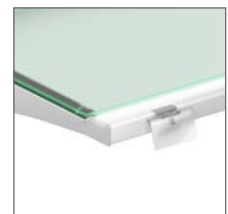

portaprezzo
price holder

ripiani su mensole serie RF

shelves on brackets PZ series

ripiano in metallo metal shelf

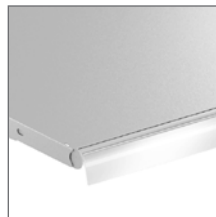
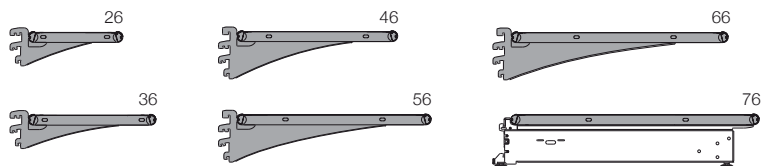
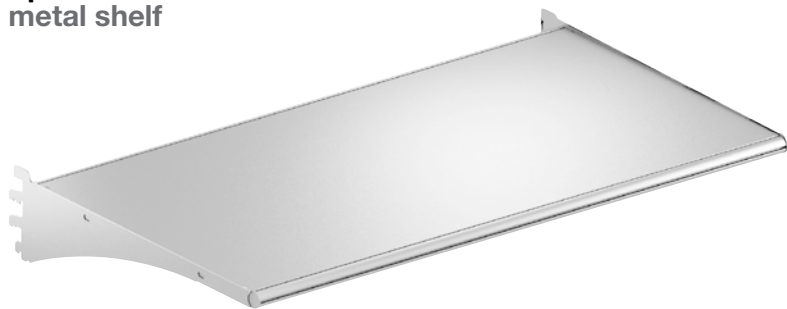

portaprezzo tutta lunghezza
overall length price holder



portaprezzo a segmento
segmented price holder



spondina e divisori in vetro
glass edge and partitions



spondina e divisori in filo
wire side and divider

ripiano in vetro glass shelf

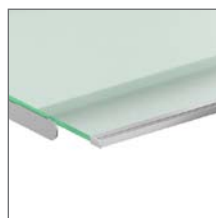
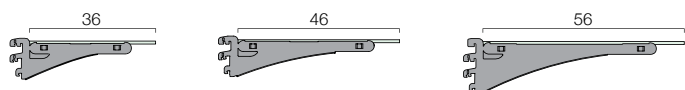

ripiano con canalino
porta accessori
shelf with
accessories groove



portaprezzo
price holder



spondina anticaduta
protective side

ripiano in vetro luminoso lit glass shelf

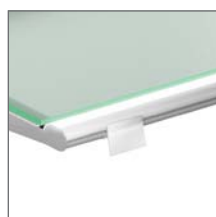
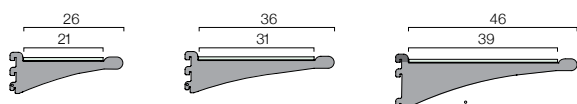

portaprezzo tutta lunghezza
overall length price holder

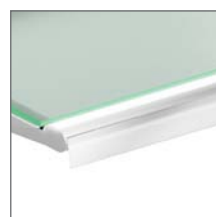

portaprezzo a segmento
segmented price holder

ripiani
shelves

ripiano in metallo forato
perforated metal shelf

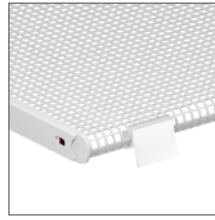
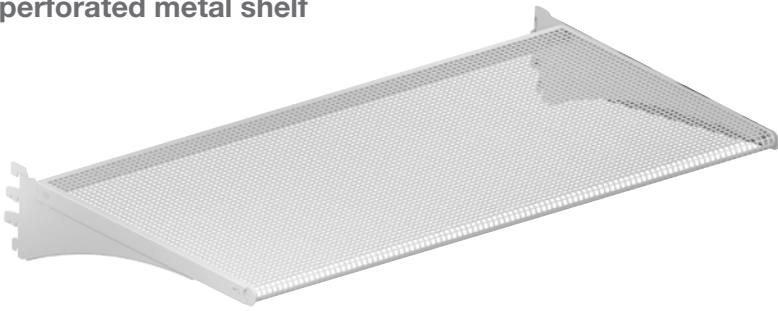

portaprezzo a segmento
segmented price holder



ripiano metallo su mensola contenitore
metal shelf on container-type support

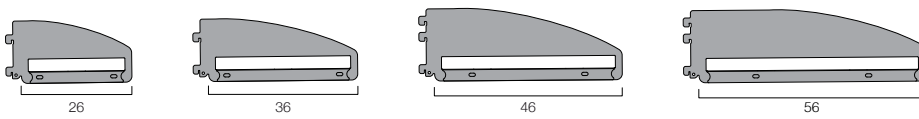
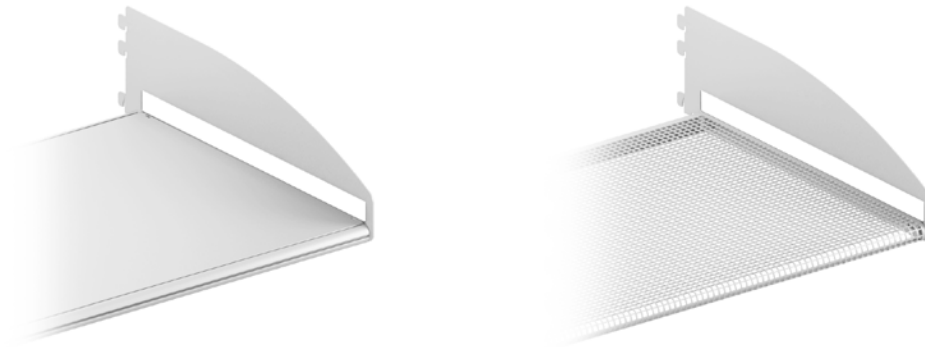

ripiano per pannello dogato
shelf for slatted panel

legno
wood

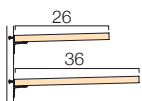

vetro
glass

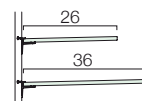

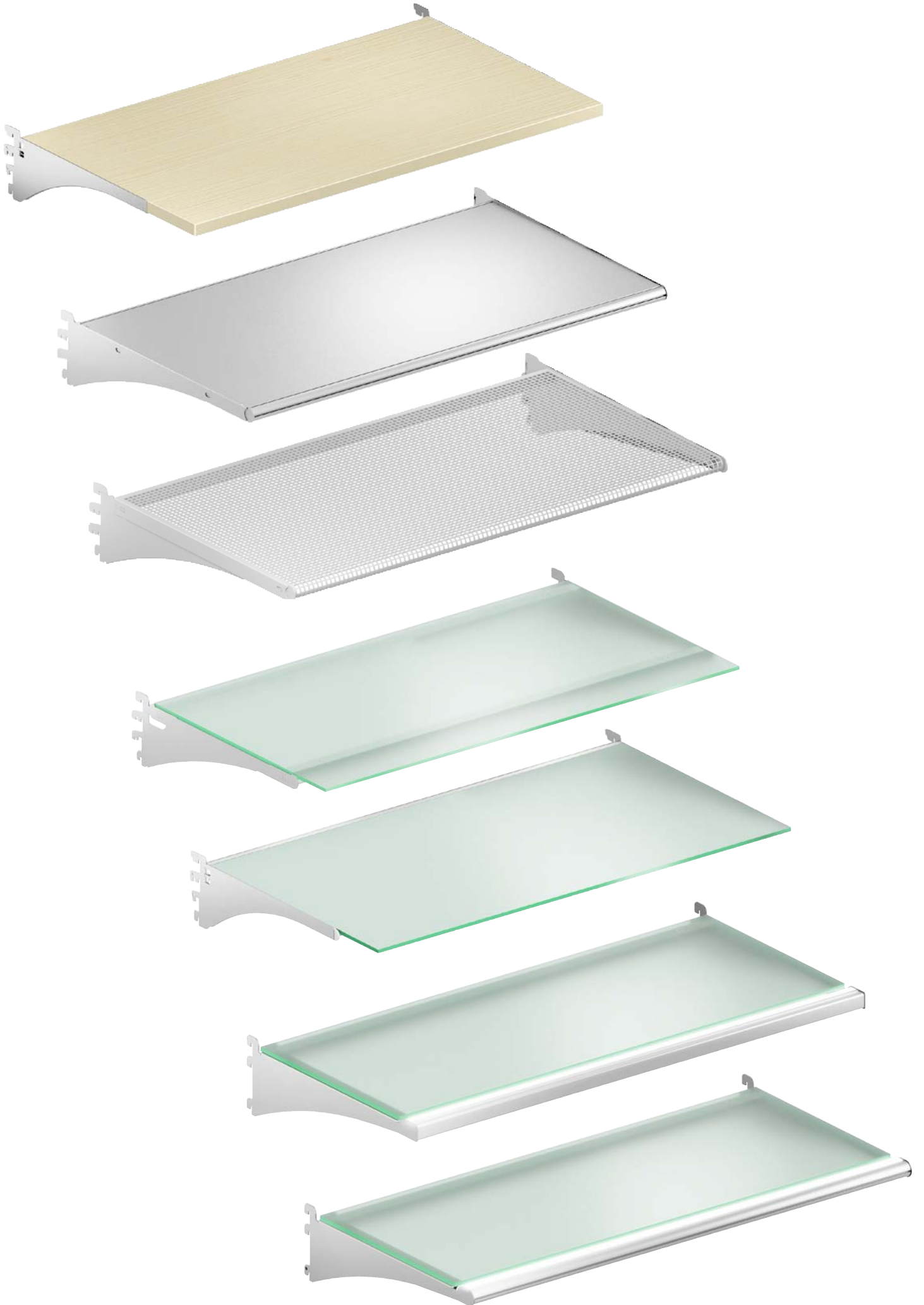

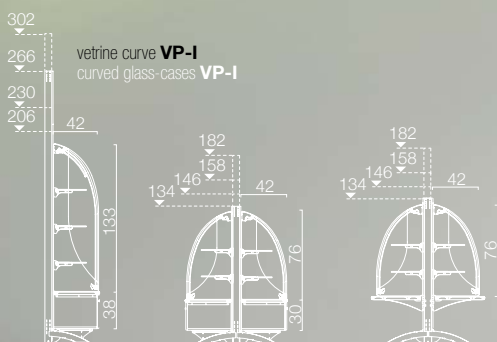



vetrine
glass-cases

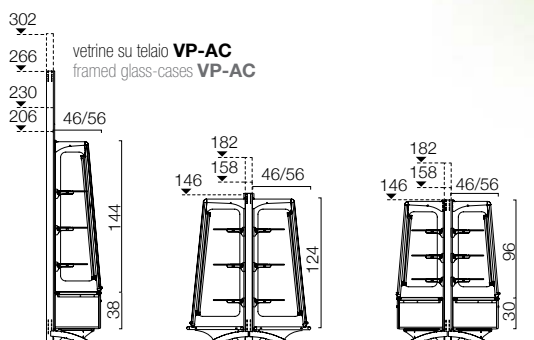

L montanti 120 = 1,3
 L montanti 70 = 6,3
 L uprights 120 = 1,3
 L uprights 70 = 6,3

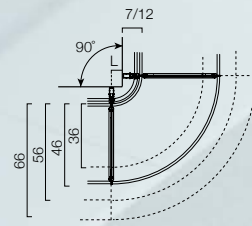

esterno 90°
external 90°

L montanti 120 = 91,5
 L montanti 70 = 87,3
 L uprights 120 = 91,5
 L uprights 70 = 87,3

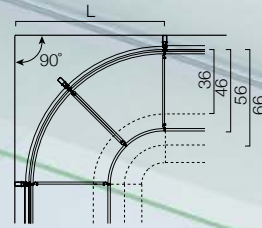

interno 90°
internal 90°



interno 45°
internal 45°

L montanti 120 = 39,4
 L montanti 70 = 36,3
 L uprights 120 = 39,4
 L uprights 70 = 36,3

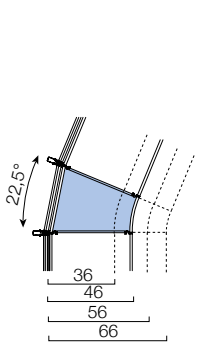

interno 22,5°
internal 22,5°

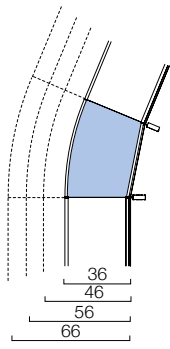

esterno 22,5°
external 22,5°

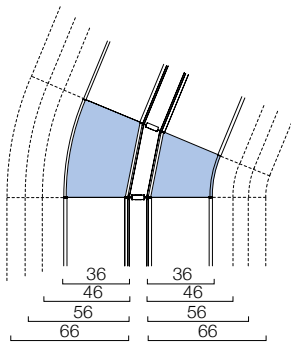

interno/esterno 22,5°
internal/external 22,5°

**angoli per gondole e
pareti curve**
corners for gondola and
curved walls

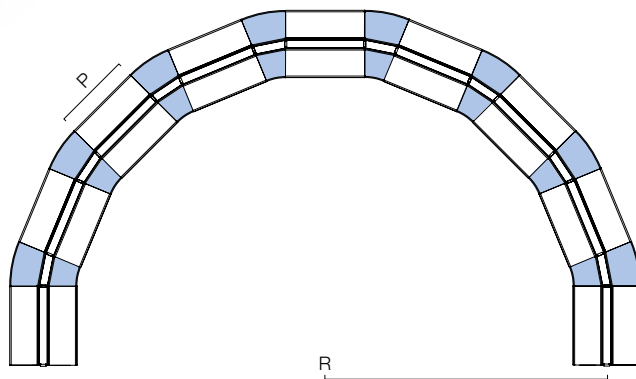
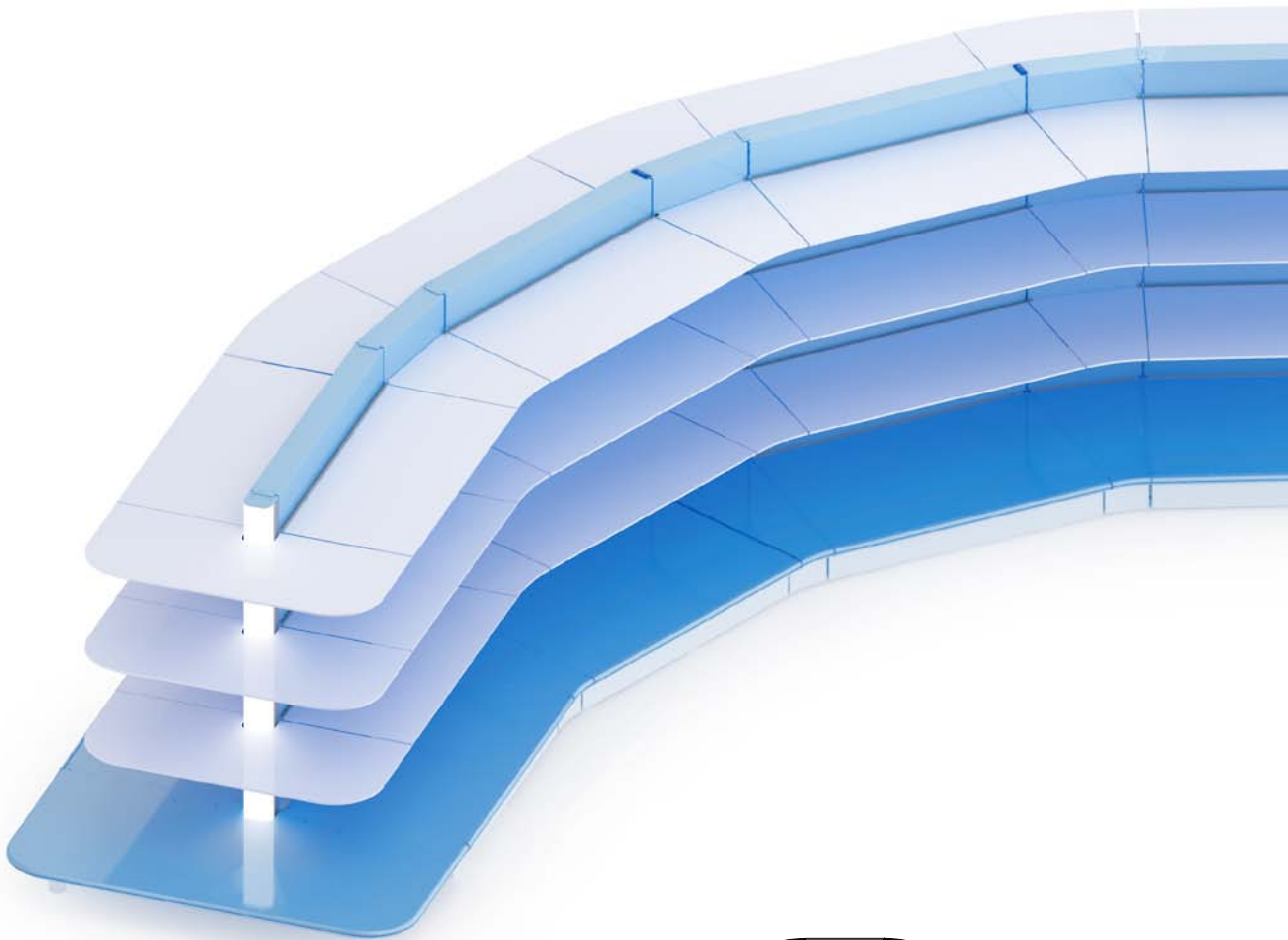

P 70	= R 2,81
P 100	= R 3,565
P 120	= R 4,065
P 133	= R 4,395
P 70+70	= R 4,565
P 70+100	= R 5,325
P 70+120	= R 5,825
P 70+133	= R 6,155
100+100	= R 6,075
P 100+120	= R 6,58
P 100+130	= R 6,905
P 120+120	= R 7,085
P 120+133	= R 7,41
P 133+133	= R 7,735

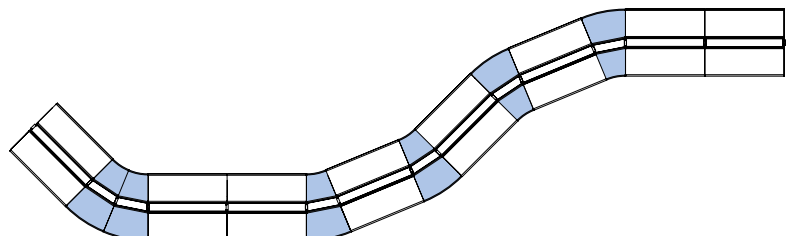

angoli e curve
corners and curves

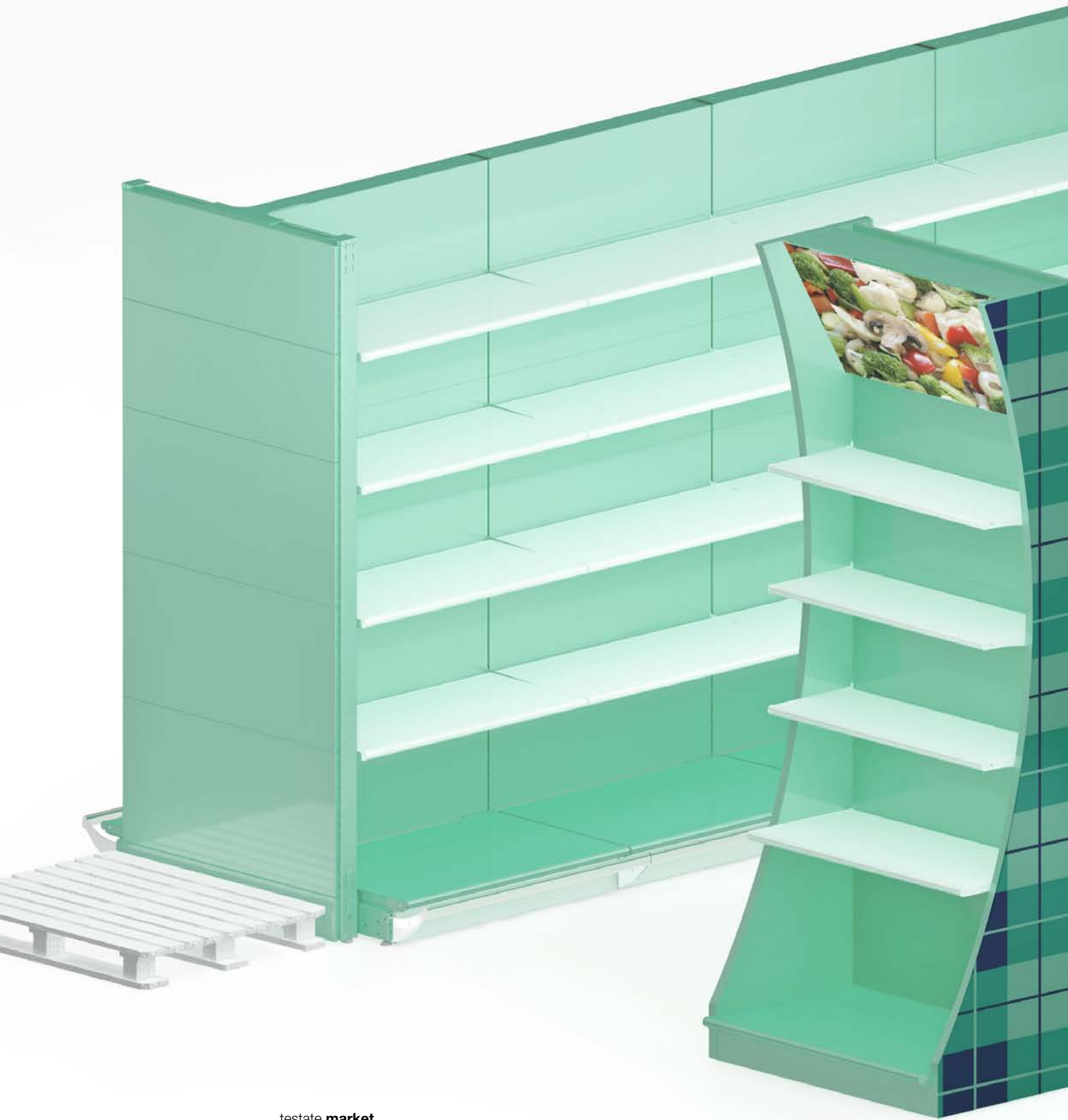

testate **market**
market heads

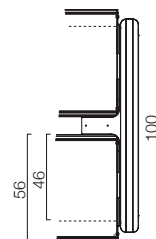
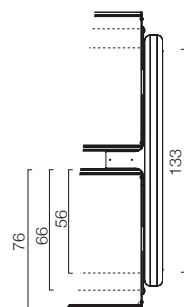
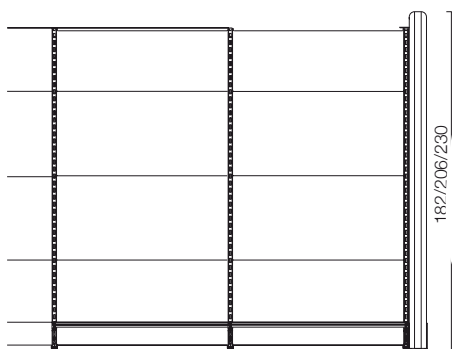



testate di gondola
gondola heads



testata **con ripiani continui**
head **with continuous shelves**

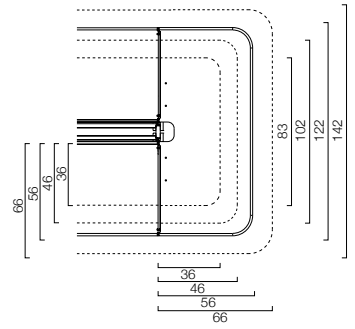

testata **con telaio asolato**
head **with slotted frame**

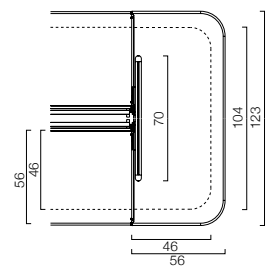
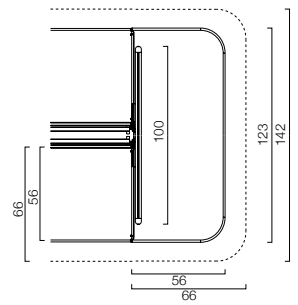



testata **con cornice**
head **with frame**

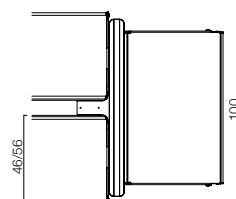
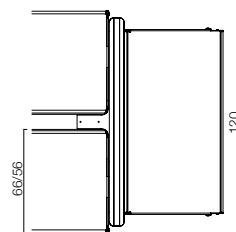

testata **con pannello dogato**
head **with slatted panel**

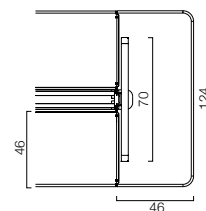
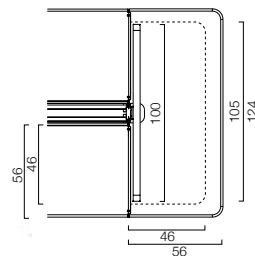

grafica su pannello
graphics on panel



schienale in aggetto luminoso
jutting lit back panel

base luminosa
lit base

schienale luminoso
lit back panel

cornice decorativa **verniciata**
painted decorative frame



schienale **luminoso graficizzato**
printed lit back panel

banner **per comunicazione**
communication banner

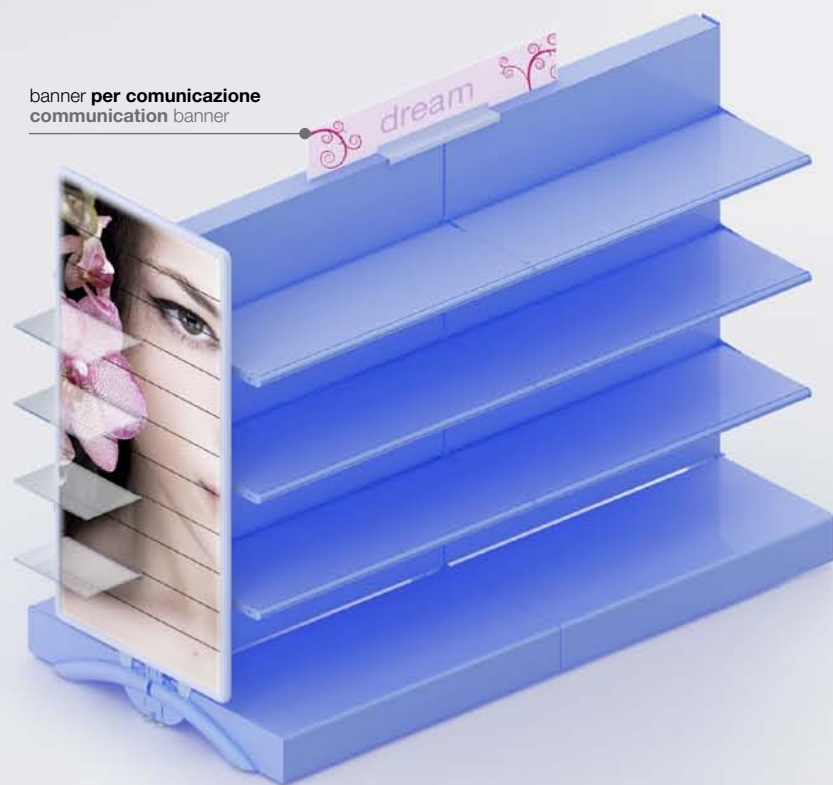

cornice **decorativa verniciata**
painted decorative frame



comunicazione e luce
communication and light

cornice **decorativa luminosa**
lit decorative frame

comunicazione **di settore**
market communication

banner **per comunicazione**
communication banner

cornice **decorativa luminosa colorata**
coloured lit decorative frame

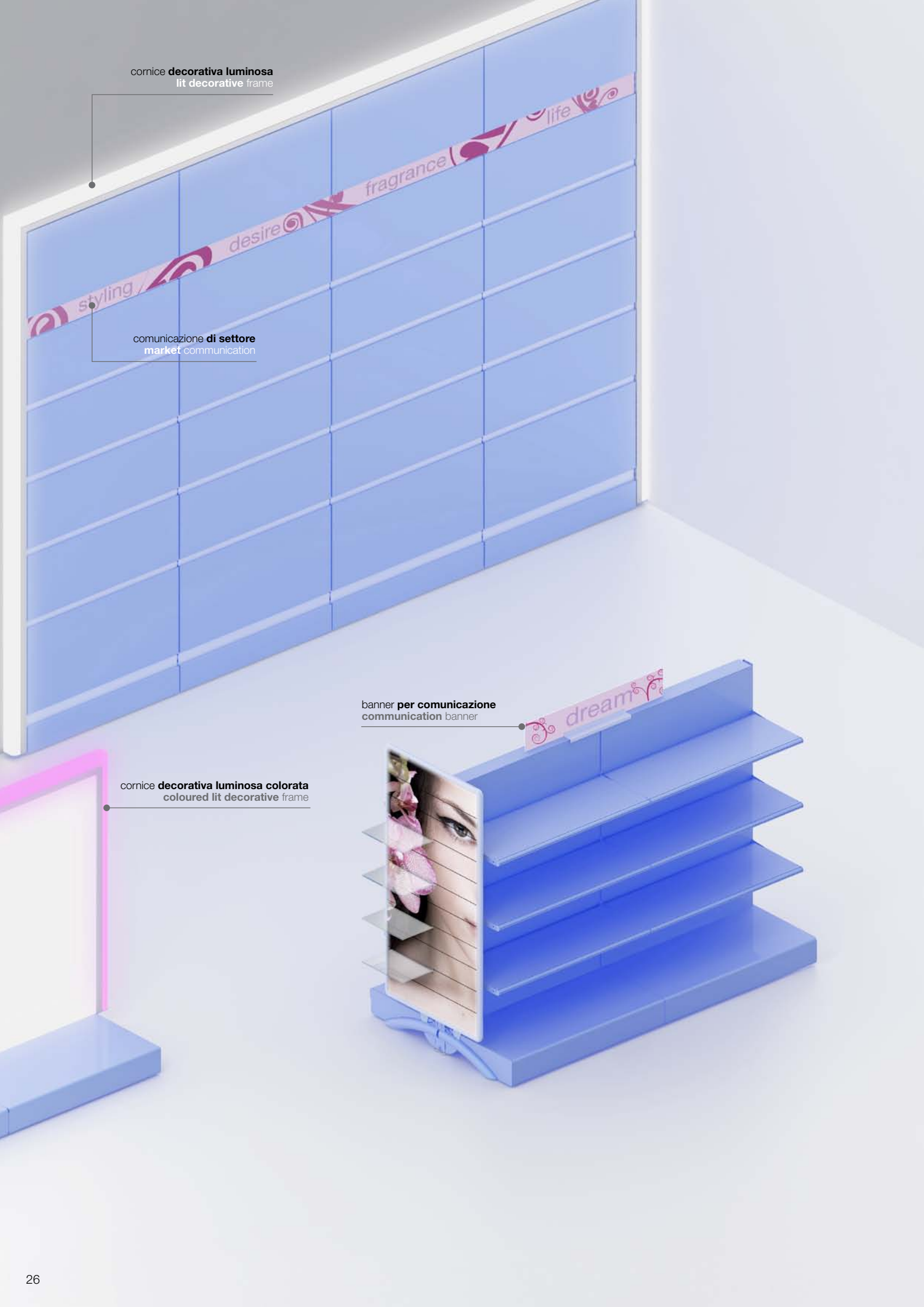



cassonetto **luminoso canalizzabile**
lit canalized box

veletta **airone**
airone canopy

veletta **tucano**
tucano canopy

schienali **luminosi e di comunicazione**
lit and communication back panels

veletta **info**
info canopy

cassonetto **in aggetto**
jutting box

cassonetto **da incasso**
built-in box



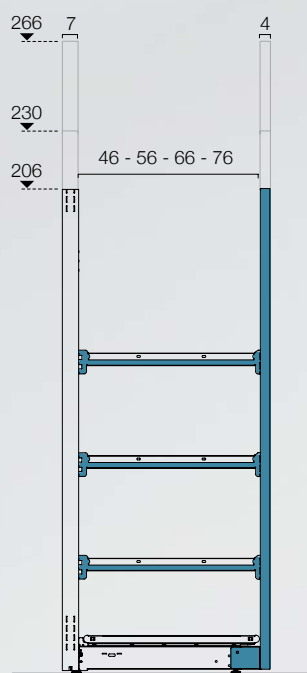

46 = 59
 56 = 69
 66 = 79
 76 = 89

con ripiani **a raso montante**
 with shelves **edging the upright**

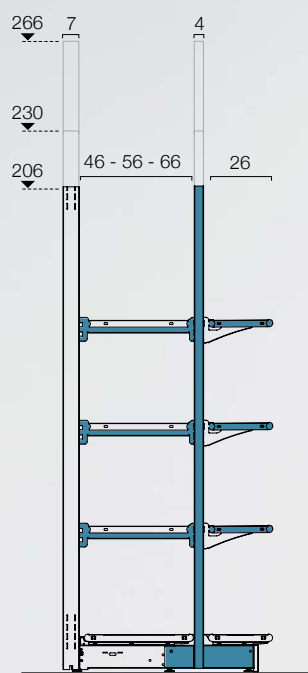

46+26 = 85
 56+26 = 95
 66+26 = 105

con ripiani **in aggetto**
 with **jutting shelves**



PER LA CASA
FOR THE HOME



CURA E BELLEZZA
BEAUTY AND CARE



ELETRONICA
ELECTRONICS



LIBRERIA
BOOKSTORE



ABBIGLIAMENTO
FASHION



GIOCATTOLI
TOYS



GDO
ORGANIZED RETAIL

PER LA CASA
FOR THE HOME



> M18

L'ATMOSFERA, INTESA
COME QUALITÀ DEGLI
SPAZI E ACCOGLIENZA,
È UN VALORE IMPORTANTE
DA TENERE PRESENTE
NELLA REALIZZAZIONE DI
MODERNI PUNTI VENDITA.

M18 OFFRE LA POSSIBILITÀ
DI RAGGIUNGERE TALI ALTI
OBIETTIVI GRAZIE ALLA
PROPRIA GAMMA DI
COLORI E FINITURE,
RISULTATO DI STUDI
QUALITATIVI APPROFONDITI.

ATMOSPHERE, WHEN
CONSIDERED AS INTRINSIC
QUALITY OF THE FURNISHED
SPACE AND ABILITY TO WEL-
COME IN, IS AN
IMPORTANT VALUE TO HAVE
IN MIND WHEN DESIGNING
MODERN POINTS OF SALE.

M18 IS THE RESULT OF A
THOUGHTFUL RESEARCH
THAT, THROUGH ITS
COLOURS AND FINISHES,
ACHIEVES SUCH
CHALLENGING HEIGHT.





> L'esposizione di prodotti dedicati alla casa risulta più attraente se organizzata alternando zone dense di prodotti ad angoli speciali che ospitano oggetti singoli esposti in modo più prezioso.

> The display of houseware is more attractive when organised by alternating areas dense with products with stand-out corners where a single item is proposed in all its charm.



PER LA CASA
FOR THE HOME





> Oggetti speciali, ceramiche smaltate e cristalli vengono valorizzati dalla luce dei ripiani luminosi.

> Peculiar items, enamelled ceramic and crystal items are enhanced by the radiance of the lit shelves.



CURA E BELLEZZA
BEAUTY AND CARE



> **M18**

- > La luce emessa dai ripiani enfatizza il prodotto e rende le esposizioni preziose ed accurate.
- > The light radiated by the shelves enhances the items and gives to the display a precious and accurate touch.





CURA E BELLEZZA
BEAUTY AND CARE



I PRODOTTI DI PROFUMERIA E DEDICATI ALLA CURA DELLA PERSONA, ACQUISTANO ULTERIORE VALORE ED IMPORTANZA RIFLETENDO SU MATERIALI PREGIATI, COME LO SPECCHIO SATINATO.

COSMETICS AND BODYCARE PRODUCTS GAIN IMPORTANCE AND VALUE WHEN THEIR SHAPE IS REFLECTED BY PRECIOUS MATERIALS, AS BY SANDED GLASS.



> Speciali elementi di comunicazione luminosi, disegnano cornici che suddividono gli spazi e incornciano il prodotto valorizzandolo.

> Lit communication elements draw frames that give value to the product.



ELETRONICA
ELECTRONICS



> M18

QUELLE CHE UN TEMPO
ERANO SEMPLICI PARETI,
DIVENTANO OGGI SCE-
NOGRAFIE CHE DEVONO
COINVOLGERE ED
EMOZIONARE IL CLIENTE.

THOSE THAT ONCE WERE
JUST SIMPLE WALL
PANELS, TODAY ARE
SCENOGRAPHIES AIMED
AT CONVINCING AND IM-
PRESSING THE CUSTOMER.



ALL'INTERNO DELLA GAMMA DI ACCESSORI È POSSIBILE TROVARE RISPOSTA ALLE ESIGENZE DI ESPOSIZIONE PIÙ COMPLESSE.

THE LARGE RANGE OF ACCESSORIES ALLOWS TO FIND THE RIGHT SOLUTION EVEN FOR ARTICULATED DISPLAY CONCEPTS.





> M18

- > Non contano le caratteristiche del prodotto da esporre, **M18** è attrezzato con un'ampia gamma di accessori.
- > The characteristics of the items to display are not a challenge for **M18**, its range of accessories is wide and complete.



ELETRONICA
ELECTRONICS



PROTEGGERE, VALORIZZANDO AL MASSIMO IL PRODOTTO IN ESPOSIZIONE ALL'INTERNO DI VETRINE DALLE CARATTERISTICHE TECNICHE ED ESTETICHE DI ALTO LIVELLO, È LA MISSIONE DI **M18**.

PROTECTING THE ITEM ON DISPLAY INSIDE A GLASS CABINET WHILST ENHANCING AT THE UTMOST ITS VALUE IS THE MISSION OF **M18**.





ELETRONICA
ELECTRONICS



> M18

> La qualità costruttiva, le caratteristiche illuminotecniche e la raffinatezza dei materiali impiegati, creano un'esposizione ideale per prodotti preziosi.

> The excellent quality of materials and technical structure and the lighting solutions make of **M18** glass cabinets the ideal display environment for precious items.





ELETRONICA
ELECTRONICS



> M18

LE CARATTERISTICHE DI **M18** SI ADATTANO ALLE MOLTEPLICI ESIGENZE DELLO SHOPPING CONTEMPORANEO.

M18 IS A FLEXIBLE SOLUTION, SUITABLE TO SATISFY THE DIVERSIFIED NEEDS OF CONTEMPORARY SHOPPING.





ELETTRONICA
ELECTRONICS

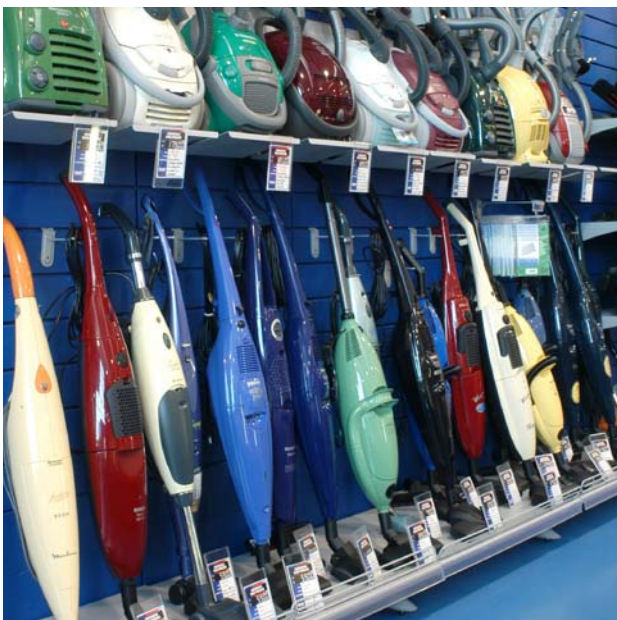



> M18

> Il design molto curato dei prodotti in vendita deve poter essere il protagonista principale. Le linee minimali di **M18** non ne sovrastano mai l'immagine, ponendosi nel giusto rapporto di equilibrio con esso.

> Here the fine design of the items on display is the protagonist. The minimalistic lines of **M18** are well balanced and never interfere with the product put on it.

LIBRERIA BOOKSTORE



> M18

L'UTILIZZO DEL SISTEMA **M18** È IDEALE PER LA DEFINIZIONE DEGLI SPAZI SETTORIALI CHE COSTITUISCONO LA TRAMA FUNZIONALE DEL NEGOZIO PER LA VENDITA DI LIBRI.

THE USE OF **M18** IS IDEAL TO THE DEFINITION OF SUBJECT AREAS WHICH ARE THE MAIN FUNCTIONAL CONCEPT IMPLEMENTED IN A BOOKSTORE.





LIBRERIA BOOKSTORE



> M18

> Per rendere semplice e ordinata l'esperienza di acquisto di un libro è necessario l'impiego di accessori espositivi in grado di evidenziare, contenere, dare gerarchia ai prodotti in vendita.

> An uncomplicated and well organised bookstore leads to a better purchase experience, that will be supported by accessories and solutions able to enhance, hold and put hierarchical order among the books.



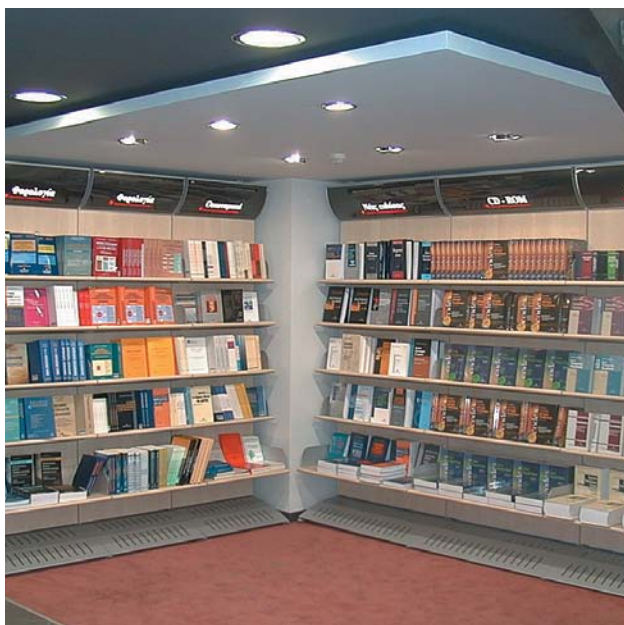

> Il mondo delle librerie offre oggi all'acquirente molti prodotti distanti dal classico libro: idee regalo, cancelleria, musica... Il sistema **M18**, capace di molteplici declinazioni sempre coordinate fra loro, si propone come prodotto ideale per l'arredo completo di questo genere di punti vendita.

> Apart from the books, nowadays the bookstore also offers stationery, music, gifts... **M18** system offers various solutions all coordinated and harmonious, an ideal choice for the furnishing of the whole bookstore.



ABBIGLIAMENTO
FASHION





**ABBIGLIAMENTO
FASHION**



LA VARIETÀ DI COLORI,
FORME E DIMENSIONI DEI
CAPI E DEGLI ACCESSORI,
CHE LA MODA OGGI
PROPONE, HA BISOGNO DI
SISTEMI PRATICI E DAL
DESIGN ACCATTIVANTE.

THE VARIETY OF COLOURS,
SHAPES AND DIMENSION
OF CLOTHING AND
ACCESSORIES PROPOSED
BY MODERN FASHION ASKS
FOR PRACTICAL SOLUTIONS
WITH CAPTIVATING DESIGN.





> M18

> **M18** dispone di elementi curati nelle finiture, in grado di soddisfare sia le esigenze estetiche che funzionali nell'esposizione del fashion.

> **M18** elements are made with a care that reaches down to the detail, so to satisfy both functional and aesthetic needs.



GIOCATTOLI
TOYS



> M18

La combinazione di ripiani e pedane centrali sono importanti per introdurre pause piacevoli nella ritmicità dei moderni punti vendita.

The combination of shelves and platforms is meant to discontinue the rigid sequence of furniture of the modern points of sale, thus giving a more pleasant feeling.



GIOCATTOLI
TOYS



M18 INTEGRA SISTEMI PER LA COMUNICAZIONE E ACCESSORI SPECIFICI CHE SI MISURANO CON GLI ASPETTI PERCETTIVI DI PRODOTTI SIA IMBALLATI CHE ESPOSTI DIRETTAMENTE.

M18 INTEGRATES COMMUNICATION SYSTEMS AND SPECIALISED ACCESSORIES, GIVING MAXIMUM EVIDENCE TO THE PRODUCTS DISPLAYED, NO MATTER IF PACKAGED OR NOT.





> M18

> Grandi pareti colorate disegnano scenografie capaci di emozionare, elemento fondamentale in un negozio di giocattoli.

> Large colorful walls draw scenographies meant to emotionate, an invaluable element for a toys shop.



> M18

> La grande distribuzione necessita di soluzioni capaci di soddisfare esigenze espositive importanti e di creare contemporaneamente atmosfere confidenziali ed accoglienti.

> Organized retail wants solutions capable to satisfy significant display needs and to create friendly and cosy atmospheres.





> I moduli curvi rompono i rigidi schemi espositivi della grande distribuzione conferendo allo spazio commerciale dinamismo e permettendo composizioni articolate su più livelli.

> The curved modules put an end to the rigid display schemes so common in the organized retail, with solutions expanded on various levels that confer momentum to the space.

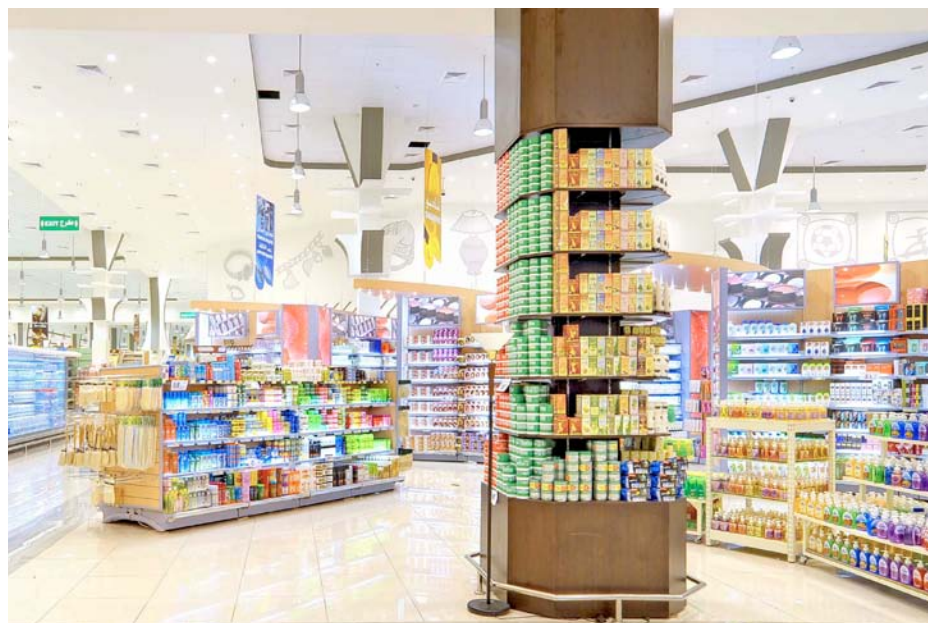



Migliorare costantemente l'esperienza di acquisto è obiettivo dei progettisti di **M18** che hanno apportato innovazione nei componenti del sistema.

> To constantly improve the purchase experience is the goal set by **M18** designers, who brought innovation to the components of the system.



M18

> Accessori dedicati, colori, luce, comunicazione, si combinano in infinite soluzioni che creano la cornice ideale per un visual merchandising efficace e di grande impatto.

> Dedicated accessories, colours, light, communication, all combined in endless solutions for an effective and successful visual merchandising.



M18

> Disegnare prospettive tese e di grande impatto visivo complessivo è possibile grazie all'utilizzo di elementi per la comunicazione innovativi e plastici.

> Flexible and innovative communication elements are at the core of captivating perspectives with great visual impact.



stampato in italia
printed in italy

© Gibam Shops srl

settembre 2013
september 2013

progetto studio tecnico Gibam Shops
layout scheme Gibam Shops technical dep.

graphic design
Zaccone Guerra Studio Associato

art direction
Nicola De Pellegrini - Anidride design

**è vietata la riproduzione totale o parziale del catalogo
senza previa autorizzazione della Gibam Shops srl**
the present printed material cannot be partially or totally reproduced
unless Gibam Shops srl has granted permission to do so

Follow us also on:



Numero Verde
800 050 640

WWW.GIBAMCOMPOSIT.IT

Gibam Composit è un prodotto:

GIBAM SHOPS SRL
VIA L.EINAUDI, SN
61032 BELLOCCHI DI FANO (PU)
TEL. +39 0721 85991
FAX +39 0721 854015

WWW.GIBAMSHOPS.IT
INFO@GIBAMSHOPS.IT

GIBAM SHOPS



 GRUPPO **GIBAM**