

sistemi e soluzioni di arredo

furnishing systems and solutions



GIBAM

 **composit**

 **M28**



Gibam Composit è un prodotto **GIBAM SHOPS**



> M28

CREATO DALLA RICERCATA COMBINAZIONE DI TECNOLOGIA, FUNZIONALITÀ ED IMMAGINE CHE CONTRADDISTINGUE GIBAM SHOPS, IL SISTEMA DI ARREDO M28 SI CARATTERIZZA PER LA LINEARITÀ E SOBRIETÀ DEL DESIGN ABBINATE ALLA MASSIMA MODULARITÀ.

> **M28** è un sistema modulare per la composizione di pareti ed espositori centrali che risponde egregiamente alle esigenze di adattabilità per la creazione di diversi stili e tendenze.

M28 si contraddistingue per la vasta gamma di materiali, colori e finiture che abbinata ad effetti di luce ed un'elevata possibilità di comunicazione rende il sistema uno strumento ideale per progettisti ed arredatori.

La ricerca di design del sistema e degli accessori lo rendono pulito, minimale ed elegante, perfetto per aderire alle più diverse esigenze di allestimento.

GIBAMSHOPS

CREATED BY THE REFINED COMBINATION OF TECHNOLOGY, FUNCTIONALITY AND IMAGE WHICH DISTINGUISHES GIBAM SHOPS, THE M28 FURNISHING SYSTEM IS CHARACTERIZED BY LINEAR AND SOBER LINES MATCHED WITH MAXIMUM MODULARITY.

> **M28** is a modular system for the composition of walls and central display units, perfectly suitable to adapt to different styles and trends.

M28 is characterized by a wide range of materials, colours and finishings that, coupled with light effects and communication solutions, make the system an ideal instrument for project managers and designers. The refined design of the system, and its accessories make it clean, minimal and elegant, perfect to comply with the most different requirements of furnishing.

LA STRUTTURA
THE STRUCTURE

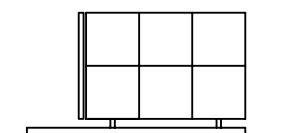
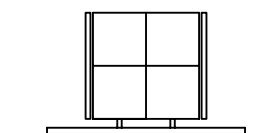
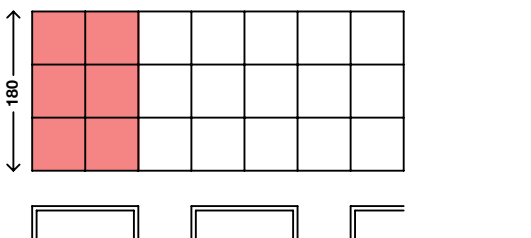
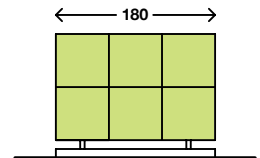
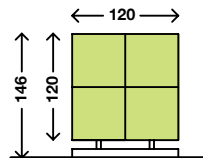
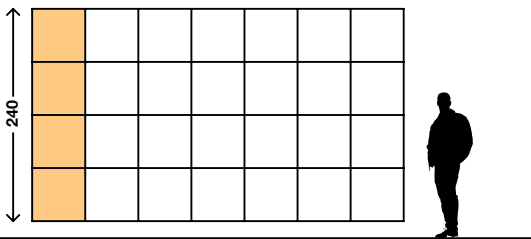
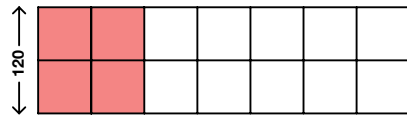
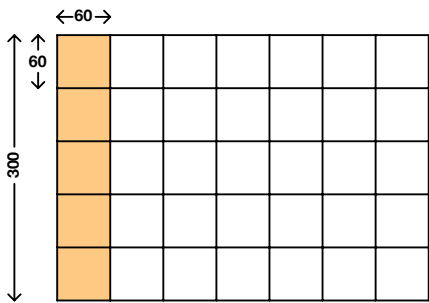

LA LUCE
THE LIGHT



PLAFONE LUMINOSO IN AGGETTO
BACKLIT JUTTING BOX



SCHIENALI LUMINOSI CON O SENZA IMMAGINE
BACKLIT PANELS WITH OR WITHOUT GRAPHICS

> M28



SISTEMA INTEGRATO DI ELETTTRIFICAZIONE SCHIENALI
INTEGRATED ELECTRIFICATION SYSTEM

GLI ACCESSORI



**asta verticale
con gancere frontali**
vertical bar for tube fittings



**barra orizzontale
con gancere frontali**
horizontal bar for tube fittings



gancera sottopiano
under-shelf support

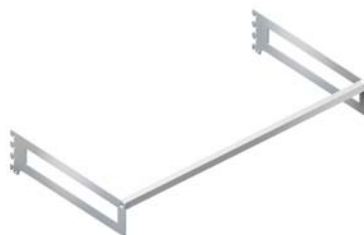

gancera longitudinale
hook-up bar



gancera longitudinale rialzata
elevated hook-up bar



plafone luminoso in aggetto
backlit jutting box



**schienale luminoso con pianetto
portascarpe integrato**
backlit panel with integrated shoe holder



contenitore di base per espositore centrale
container shelf for central display unit

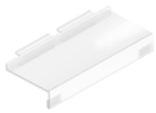

pianetto portascarpe per doghe
shoe holder for slat panels



ripiani in legno per doghe
wooden shelves for slat panels



ripiani in vetro per doghe
glass shelves for slat panels



ripiani in vetro luminosi
glass shelves with front light



ripiani in legno con mensola planare
glass shelves with embedded bracket



ripiani in vetro con mensola planare
wood shelves with embedded bracket



ripiani in metallo con mensola contenitore
metal shelves with container bracket



ripiani in vetro con mensola contenitore
glass shelves with container bracket



ripiani in legno con mensola contenitore
wooden shelves with container bracket



ripiani in metallo
metal shelves

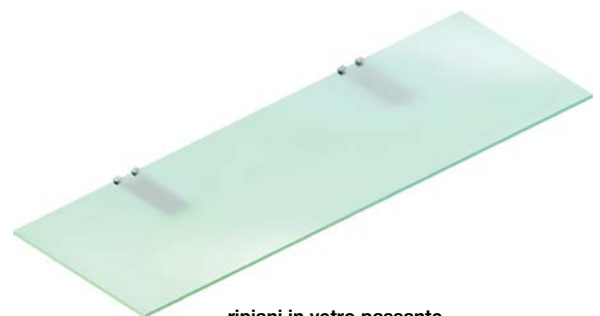

ripiani in vetro passante
large glass shelves

gancere in filo
hooks



**COLORI
E MATERIALI**
COLOURS
AND MATERIALS



> **M28**

> L'elevata disponibilità di colori e finiture, assicura le più ampie possibilità di personalizzazione dando luogo ad un'incredibile gamma di soluzioni estetiche e cromatiche.

> The wide range of colours and finishings available guarantees the largest possibilities of customization creating an incredible range of aesthetical solutions.

**COLORI
E MATERIALI**
COLOURS
AND MATERIALS

Gli esempi riprodotti in queste pagine, rappresentano i materiali applicabili al sistema M28. È disponibile un'ampia gamma di colori e finiture. I colori riprodotti in queste pagine sono puramente indicativi.

The images shown in these pages represent the materials applicable to the M28 system. A wide range of colours and finishings is available. The colours shown in these pages are purely indicative.

schienali
legno

wooden
back panels



melaminico tinte legno
wood patterns melamine

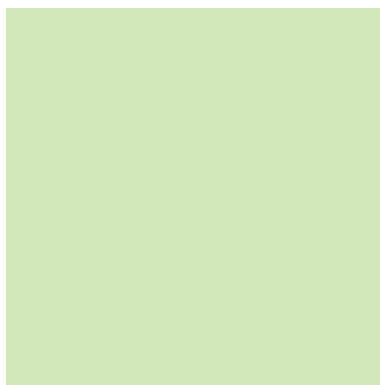

melaminico tinte unite
solid colours melamine panels



melaminico lucido
glossy melamine panels

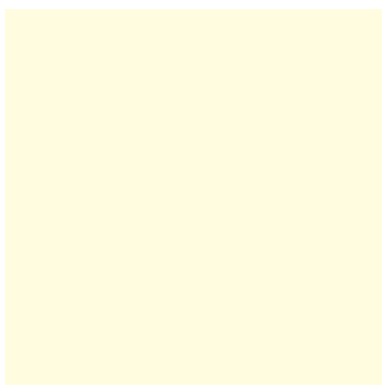

laccato lucido
gloss lacquered panels

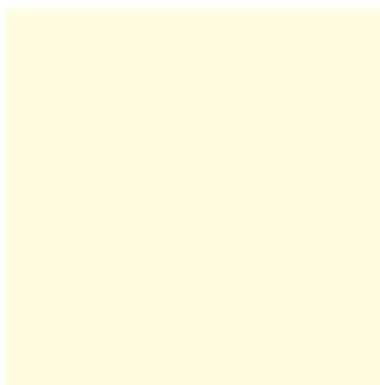

laccato opaco
matt lacquered panels



tutti i laminati plastici
All plastic laminated

**COLORI
E MATERIALI**
COLOURS
AND MATERIALS

schienali
metallo

metal
back panels



liscio in lamiera verniciata
smooth coated panels

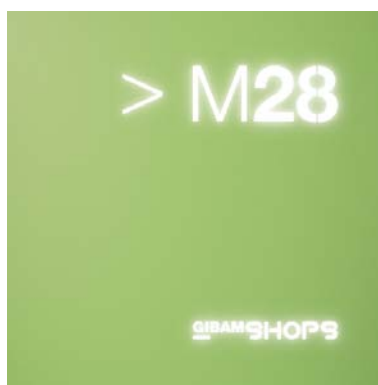

**liscio con incisioni personalizzate
in lamiera verniciata**
smooth coated panels with custom-
made engravings

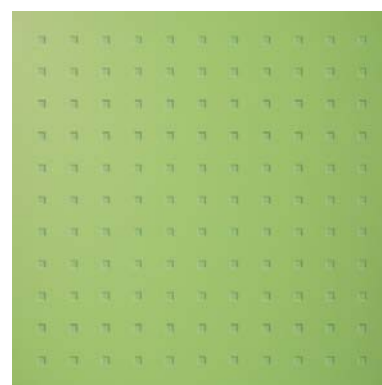

bugnato in lamiera verniciata
raised pattern coated metal

schienale
a doghe alluminio

aluminium
slat back panel

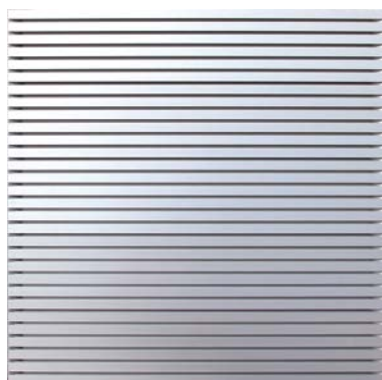

alluminio anodizzato
anodized aluminium

**COLORI
E MATERIALI**
COLOURS
AND MATERIALS

schienali
alluminio

aluminium
back panels

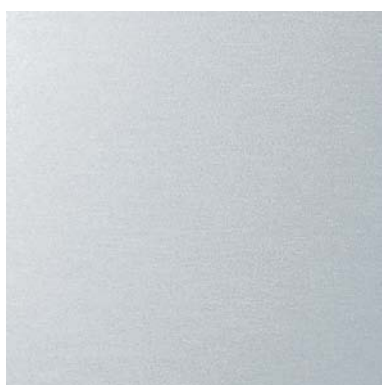

liscio in alluminio satinato
smooth satin aluminium



**liscio con incisioni personalizzate
in alluminio satinato**
smooth satin aluminium panels with
custom-made engravings

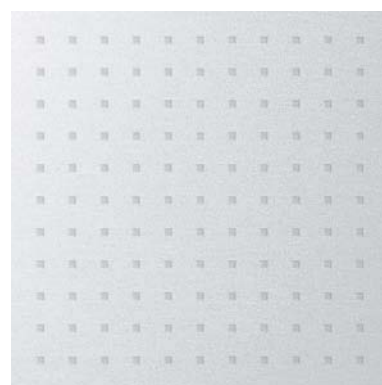

bugnato in alluminio satinato
raised pattern satin aluminium

schienali rivestiti
in ecopelli o tessuti

eco-leathers
and fabrics covered back panels



ecopelle
eco-leather panels

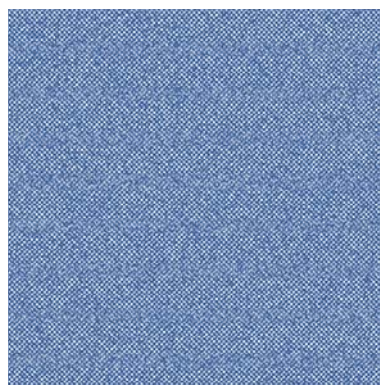

tessuto
fabric panels

**COLORI
E MATERIALI**
COLOURS
AND MATERIALS

schienali
vetro

glass
back panels



specchi
mirrors



retro-verniciati
rear-coated glasses



decorati
decorated glasses

schienali rivestiti
in ecopelli o tessuti

eco-leathers
and fabrics covered back panels



stratificato con tessuto
wood covered with fabric

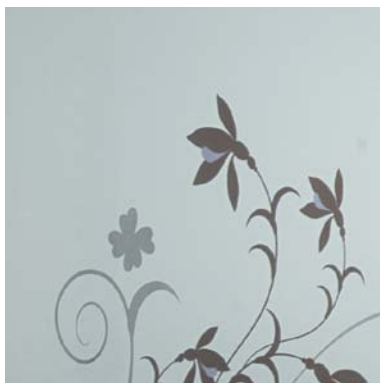

specchi con stampa digitale diretta
digitally printed mirrors

**COLORI
E MATERIALI**
COLOURS
AND MATERIALS

schienali
plexiglas

methacrylate
back panels

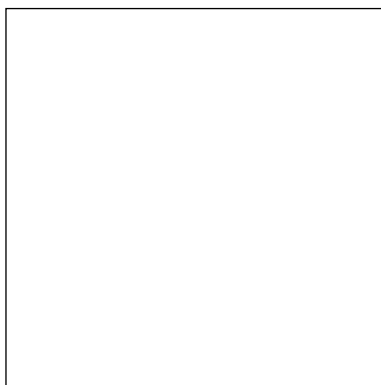

opalino
milky



Opalino con stampa digitale diretta
matt digitally printed



colorati
tinted

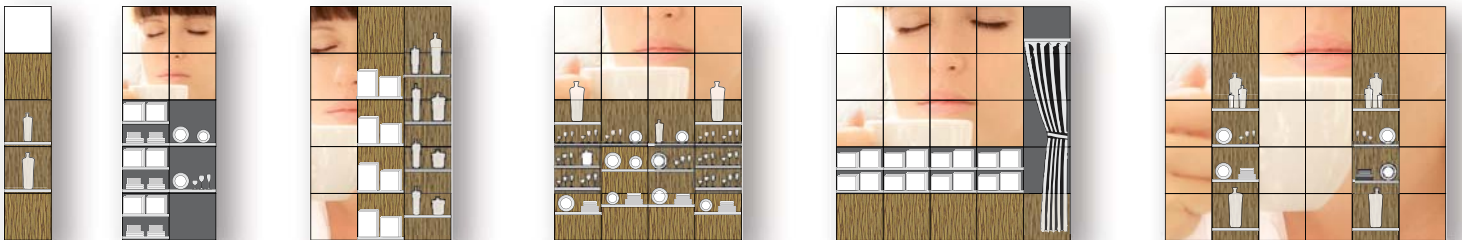



> L'abbinamento di materiali caldi o etnici, come il legno, e materiali tecnologici, come l'alluminio, permettono la realizzazione di ambienti raffinati ed accoglienti.

> THE COMBINATION OF WARM OR ETHNICAL MATERIALS SUCH AS WOOD, AND TECHNOLOGIC MATERIALS SUCH AS ALUMINIUM, ALLOWS THE CREATION OF REFINED AND PLEASANT SHOPFITTING SOLUTIONS.

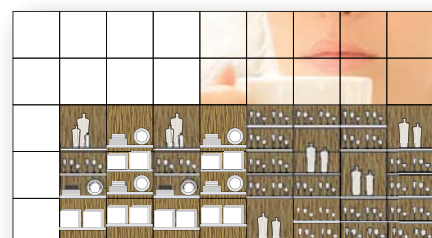
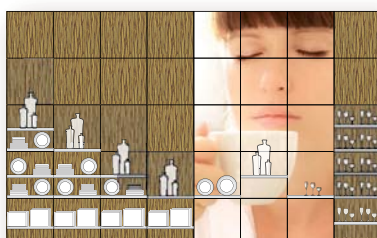
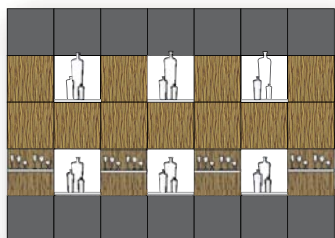



> GLI ACCESSORI, PERFETTAMENTE COORDINATI ALLO STILE GEOMETRICO E RAZIONALE DEL SISTEMA, COMPLETANO CON SEMPLICITÀ E PULIZIA I PIÙ ACCATTIVANTI ALLESTIMENTI.

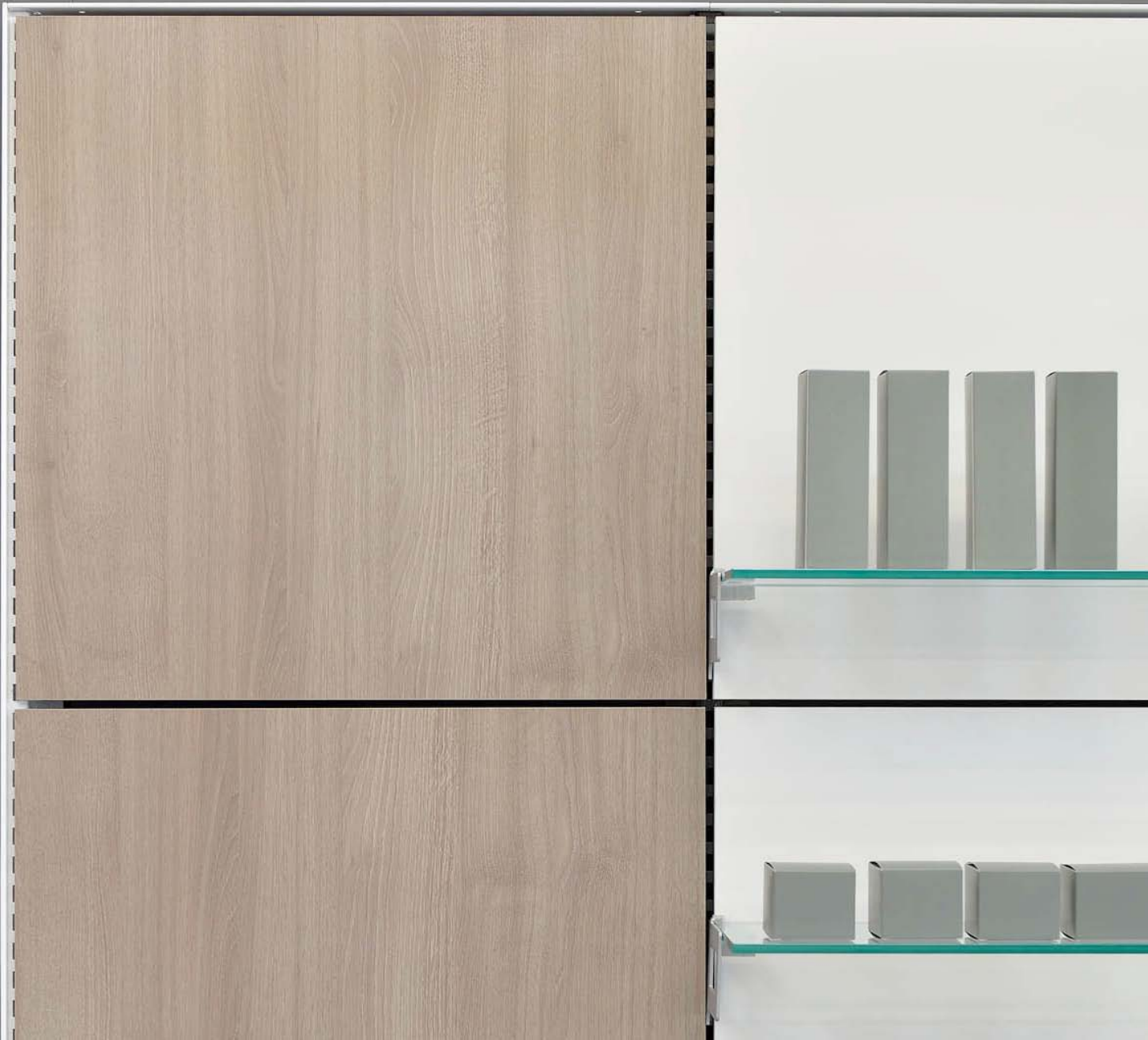

> The accessories, perfectly matching with the geometrical and rational style of the system, are the simple and sober completion of the most fascinating decorations.

> M28

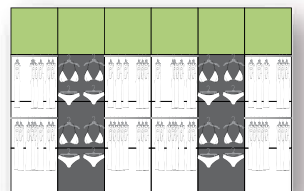
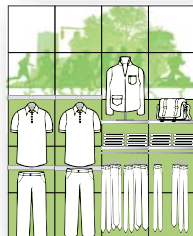

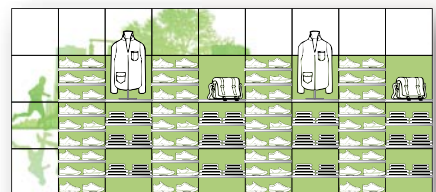



>M28



> LA VASTA POSSIBILITÀ DI COMUNICAZIONE, AFFIDATA A GRANDI PANNELLI LUMINOSI COMBINABILI, PERMETTE DI OTTENERE UN'IMMAGINE DI FORTE IMPATTO RENDENDO SEMPLICE ED IMMEDIATA LA POSSIBILITÀ DI COORDINAMENTO CON IL BRAND E CON LE SPECIFICHE ESIGENZE DI AMBIENTAZIONE.

> The large backlit panels are at the core of a wide range of communication solutions of great impact. It is so simple to adhere to brand image requirements.







> L'utilizzo del vetro, abbinato a finiture dai colori freddi, si presta alla creazione di ambienti al tempo ariosi ed eleganti.





> IL PRODOTTO SI RIFLETTE SU MATERIALI PREGIATI, COME LO SPECCHIO SATINATO, ACQUISTANDO ULTERIORE VALORE ED IMPORTANZA. LA LUCE EMessa DAI RIPIANI RENDE IL PRODOTTO PROTAGONISTA ASSOLUTO PERMETTENDO ESPOSIZIONI PREZIOSE ED ACCURATE.

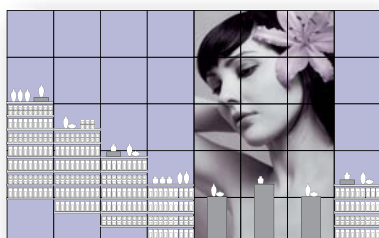



>M28



> The use of glass, joined to cold colour finishing, is ideal for the creation of display sets that are airy and elegant at the same time.

> THE PRODUCT IS REFLECTED ON THE BACKGROUND OF PRECIOUS MATERIALS, AS GLAZED MIRRORS FOR EXAMPLE, GAINING MORE VALUE AND IMPORTANCE. THE LIGHT EMITTED BY THE SHELVES MAKES THE PRODUCT THE ONLY PROTAGONIST AND GIVES A PRECIOUS AND ACCURATE DISPLAY.





> La perfetta integrazione di luce e comunicazione con l'elevata disponibilità di colori, materiali ed accessori, rende M28 la cornice ideale per l'esposizione delle più svariate merceologie, creando pareti modulari uniche e suggestive.

> The perfect integration of light and communication along with the considerable number of colours available make M28 the ideal framework for displaying different marketable goods, creating unique and suggestive modular walls.

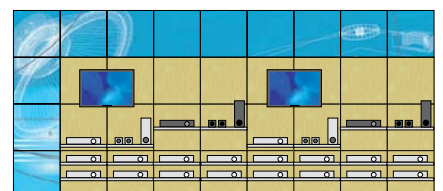
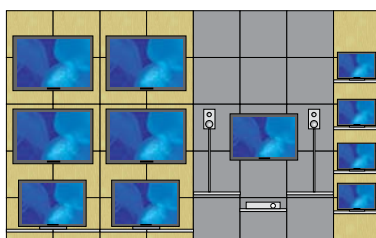
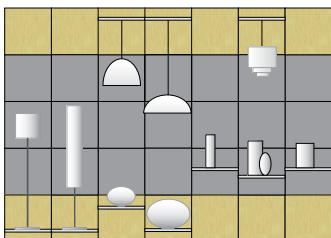



> M28

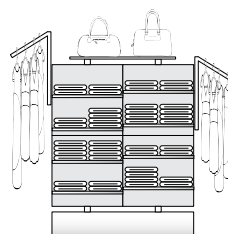
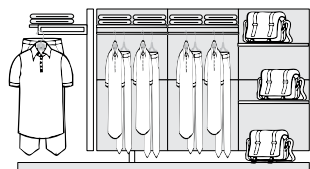
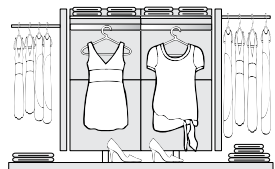

> GLI ESPOSITORI CENTRALI RIFLETTONO LA GEOMETRIA PERFETTA E MINIMALE DI TUTTO IL SISTEMA, DETERMINANDO IL CARATTERE DEL PRODOTTO ESPOSTO E PERFEZIONANDO L'ATMOSFERA GENERALE E LE ESIGENZE ESPOSITIVE.

> THE CENTRAL DISPLAY UNITS REFLECT THE PERFECT AND MINIMAL GEOMETRY OF THE ENTIRE SYSTEM, DEFINING THE NATURE OF THE PRODUCT DISPLAYED AND PERFECTING BOTH GENERAL ATMOSPHERE AND DISPLAY REQUIREMENTS.

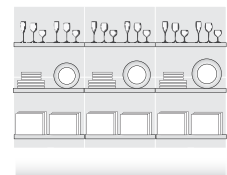
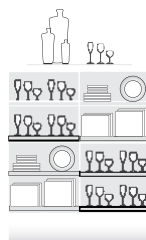
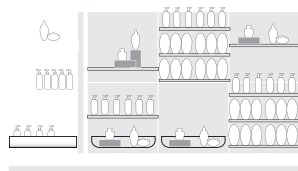
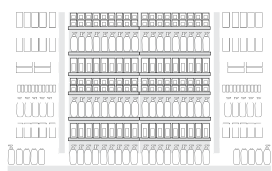

SCHEMA DI
MONTAGGIO
ASSEMBLING
DIAGRAM

pareti

walls

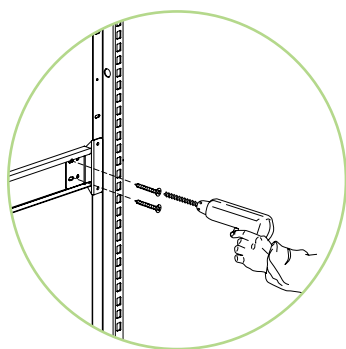
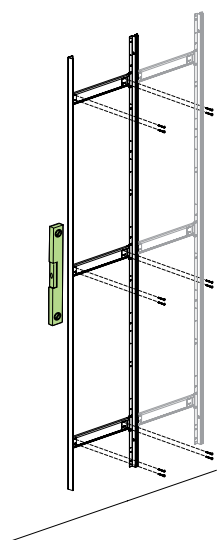

1) Fissare il primo passo e passi successivi a muro con tasselli e viti adeguate alla tipologia della parete.

1) Fix the uprights and the horizontal profiles with nogs and screws suitable to the wall typology.

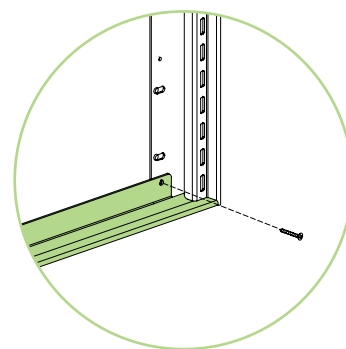
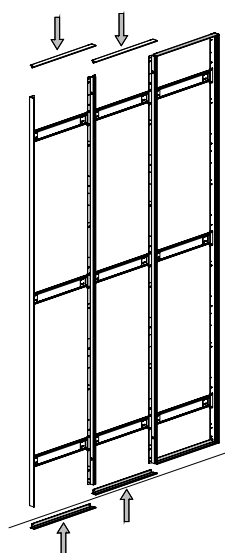

2) Fissare le cornici terminali e centrali.

2) Fix the end and central frames.

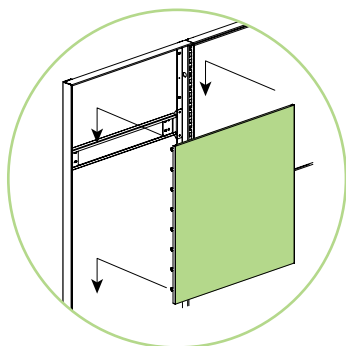
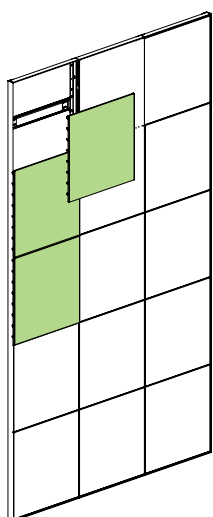

3) Inserire gli schienali.

3) Insert the panels.

espositori centrali

central display

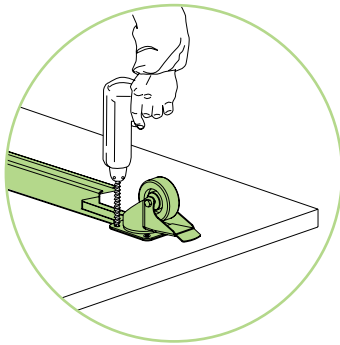
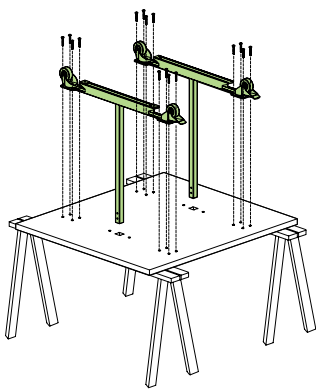

A) Inserire il kit piedi sulla piana base.

A) Insert the feet kit onto the base platform.

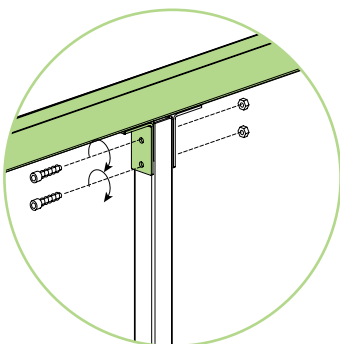
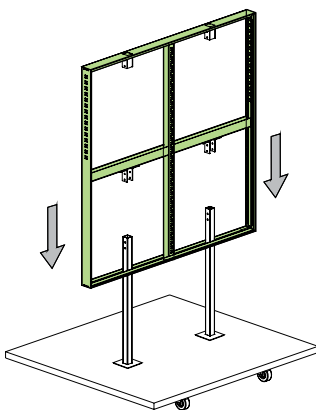

B) Inserire il telaio e bloccare con le apposite viti.

B) Insert the frame and block with the supplied screws.

stampato in italia
printed in italy

© Gibam Shops srl

settembre 2013
september 2013

progetto studio tecnico Gibam Shops
layout scheme Gibam Shops technical dep.

graphic design
Zaccone Guerra Studio Associato

art direction
Nicola De Pellegrini - Anidride design

photo
Andrea Franceschetti

**è vietata la riproduzione totale o parziale del catalogo
senza previa autorizzazione della Gibam Shops srl**
the present printed material cannot be partially or totally reproduced
unless Gibam Shops srl has granted permission to do so

Follow us also on:



Numero Verde
800 050 640

WWW.GIBAMCOMPOSIT.IT

Gibam Composit è un prodotto:

GIBAM SHOPS SRL
VIA L.EINAUDI, SN
61032 BELLOCCHI DI FANO (PU)
TEL. +39 0721 85991
FAX +39 0721 854015

WWW.GIBAMSHOPS.IT
INFO@GIBAMSHOPS.IT

GIBAM SHOPS



 GRUPPO **GIBAM**