

netwall

la parete ha un'anima the wall has an internal part

CEAN
COMPANY
SHOP TECHNOLOGY



NETWALL STYLE LINEARITY. The combination of the panel board outline for the **netwall** permits a continuous solution for walls, a successful formula, from the essential style studied to subdivide internal spaces in businesses.

An outline in extruded aluminium, barely visible to the soul, a groove with a high buttonhole to position the shelves and dull, stain-steel hooks, able to be mounted in two ways and remains the same over the passage of time (support drywall) are the details of the **netwall** study that emerges in an elaboration from a surprising, aesthetic result: a fissure of 5mm on a coplanar surface wall that is not conditional in any way, with protrusions, the same linearity.

In order to separate the spaces, with aesthetic value of professionalism of Cean, a composition to explore sophisticated workmanship. Technological research and commercial efficacy for a stylish wall.

netwall linearità di stile



L'accostamento di pannelli in cartongesso ai profili **netwall** consente soluzioni di continuità a parete; una formula di successo, dallo stile essenziale studiato per suddividere gli spazi all'interno dei negozi.

Un profilo di alluminio estruso, appena percettibile nella sottile anima, una gola con asole alte per agganciare le mensole e gancere realizzate in acciaio inox satinato, inalterabile nel tempo e predisposto per essere inserito a due montanti (ordinatura portante del cartongesso) sono i dettagli dello studio di **netwall** che emergono in una elaborazione dal sorprendente risultato estetico: una fessura di 5 mm coplanare alla superficie della parete che non condiziona in alcun modo, con sporgenze, la linearità della stessa. Per separare gli spazi, con il valore estetico della professionalità di Cean, una composizione da esplorare nella sua sofisticata lavorazione.

Ricerca tecnologica ed efficacia commerciale per una parete di stile.





netwall

fasi di montaggio

phases of assembling



Fase 1
Fissaggio profili
Phase 1
Outline fixings



Fase 2
Fissaggio pannelli
Phase 2
Panel board fixings



Fase 3
Stuccatura con protezione profilo
Phase 3
Surfacing with outline protection



Fase 4
Tinteggiatura con protezione profilo
Phase 4
Painting with outline protection



Fase 5
Distacco protezione
Phase 5
Detachment protection

catalogo tecnico technical catalogue

indice index

| | |
|--|----|
| Simbologia dei materiali Materials symbols | 2 |
| Istruzioni per la lettura del listino How to read the catalogue | 3 |
| Profilo a cremagliera per pareti in cartongesso Rack profile for plasterboard wall | 4 |
| Accessori per cremagliera Accessories for rack | 6 |
| Accessori per barra orizzontale Accessories for horizontal rod | 10 |
| Piastre di aggancio per pannelli Connection plate for panels | 12 |
| Condizioni generali di vendita General terms of sale | 14 |

-  **Metallo zincato**
Galvanized metal
-  **Alluminio anodizzato**
Anodised aluminium
-  **Materiale grezzo**
Raw material
-  **Metallo verniciato con polveri epossidiche colore JA**
Painted metal with a colour epoxy paint
-  **Vetro trasparente**
Transparent glass
-  **Vetro acidato**
Glazed glass
-  **Metallo spazzolato**
Brushed steel metal
-  **Materiale plastico trasparente**
Transparent plastic material

Istruzioni per la lettura del listino

How to read the catalogue

Capoverso
Paragraph

Istruzioni di montaggio
Assembly instructions

Componenti
Components

Specifiche particolari
Special specifications

Tabella colori di riferimento
Colours chart reference

Simboli dei materiali
Symbols of materials

Programma
Net Wall

Profilo a cremagliera per pareti in cartongesso
Rack profile for plasterboard wall

Schema di utilizzo
Diagram about use

Profilo a cremagliera per pareti in cartongesso
Rack profile for plasterboard wall

Listello per rasatura
Strip for trimmings

Intervalle tra i profili consigliati di 60 cm.
Recommended intervals between panels 60 cm.

Il profilo va inserito tra 2 dei montanti che vengono usati per la realizzazione delle pareti in cartongesso, fissandolo lateralmente con viti autofilettanti.
Put the profile between 2 uprights used to realize plasterboard walls and fix it laterally with self-threaded screws.

Intervalle il listello in legno per coprire la cremagliera digitale la fare al rasatura. Prima della rasatura estrarre il listello e mantenerlo esattamente il posto.
Put the wooden strip to cover rack during trimmings. Before removing wall extract the strip, because any deterioration and pit ruin the strip.

Realizzare la struttura portante fissare i pannelli in cartongesso in modo che la cremagliera del profilo rimanga in vista.
After making the load-bearing structure fix the plasterboard sheets so that rack remains at sight.

Programma
Net Wall

Profilo a cremagliera per pareti in cartongesso
Rack profile for plasterboard wall

Listello per rasatura
Strip for trimmings

Specifiche
Details

Al fine di evitare scarti i profili legno devono sovrapporsi fra di 2,5 cm fra le code.
To avoid errors, profiles can be overlapped maintaining pitch of 2,5 cm between ends.

| P | H | L | Codice | Code |
|---|---|---|--------|----------|
| 1 | 2 | 3 | 4 | |
| | | | 300 | 1G27 001 |
| | | | 300 | 1G27 002 |

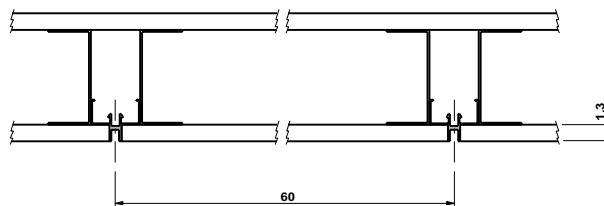
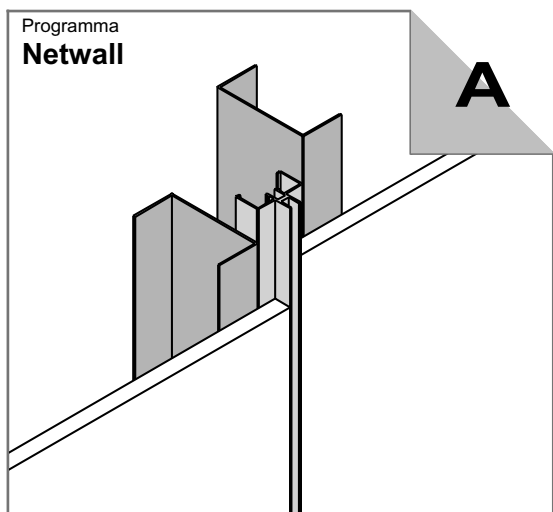

Interasse tra i profili consigliato di 60 cm.
Recommended wheelbase between panels 60 cms.

Schema di utilizzo

Diagram about use

Profilo a cremagliera per pareti in cartongesso
Rack profile for plasterboard wall

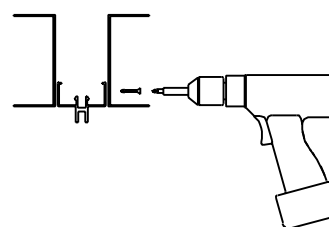
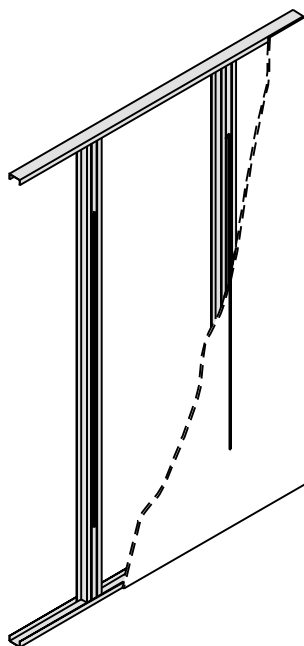

Il profilo va inserito tra 2 dei montanti che vengono usati per la realizzazione delle pareti in cartongesso, fissandolo lateralmente con viti autofilettanti.
Put the profile between 2 uprights used to realize plasterboard walls and fix it laterally with self-threaded screws.

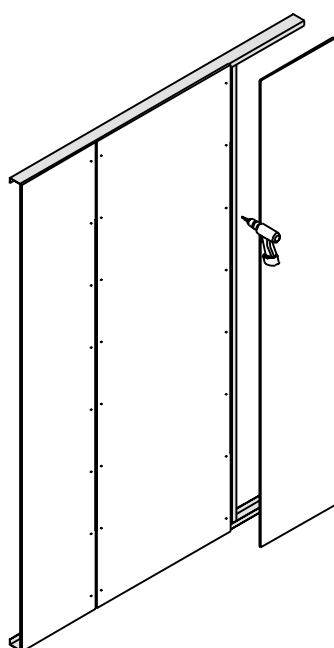

Listello per rasatura
Strip for trimmings

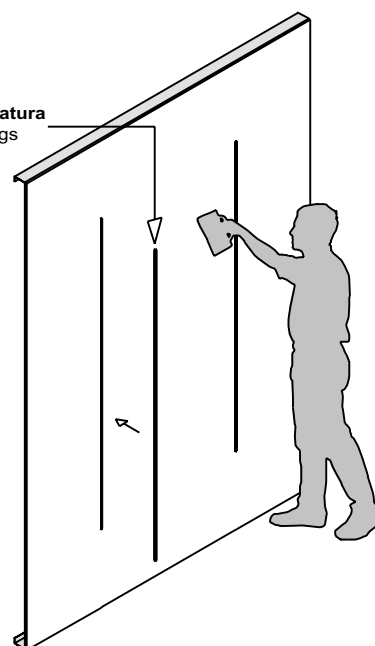

Realizzata la struttura portante fissare i pannelli in cartongesso in modo che la cremagliera del profilo rimanga in vista.
After realizing the load bearing structure fix the plasterboard panels so that rack remains at sight.

Inserire il listello in legno per coprire la cremagliera durante la fase di rasatura. Prima della verniciatura della parete è consigliabile estrarre il listello, sistemare eventuali imperfezioni vicino al profilo e reinserire nuovamente il listello.
Put the wooden strip to cover rack during trimmings. Before varnishing wall extract the strip, arrange any imperfections and put again the strip.

Profilo a cremagliera per pareti in cartongesso

Rack profile for plasterboard wall

Programma
Netwall

Specifiche
Details

| P | H | L | Codice Code | c1 | c2 | c3 | c4 |
|---|---|---|-------------|----|----|----|----|
|---|---|---|-------------|----|----|----|----|

Profilo a cremagliera per pareti in cartongesso

Rack profile for plasterboard wall

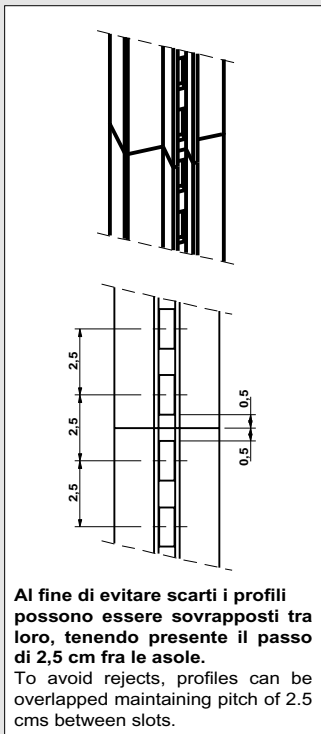
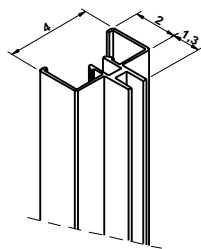

Al fine di evitare scarti i profili possono essere sovrapposti tra loro, tenendo presente il passo di 2,5 cm fra le asole.
To avoid rejects, profiles can be overlapped maintaining pitch of 2.5 cms between slots.

Listello per rasatura

Strip for trimmings

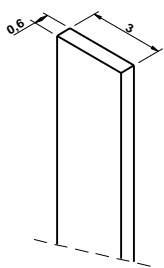

| | | | | | | | |
|--|-----|----------|--|--|--|--|---|
| | | | | | | | |
| | | | | | | | |
| | 300 | 1G27 001 | | | | | ◆ |
| | | | | | | | |
| | | | | | | | |
| | | | | | | | |
| | | | | | | | |
| | | | | | | | |
| | | | | | | | |
| | | | | | | | |
| | | | | | | | |
| | | | | | | | |
| | | | | | | | |
| | | | | | | | |
| | | | | | | | |
| | | | | | | | |
| | | | | | | | |
| | | | | | | | |
| | | | | | | | |
| | | | | | | | |
| | | | | | | | |
| | | | | | | | |
| | | | | | | | |
| | | | | | | | |
| | | | | | | | |
| | | | | | | | |
| | 300 | 1G27 002 | | | | | └ |
| | | | | | | | |
| | | | | | | | |
| | | | | | | | |
| | | | | | | | |
| | | | | | | | |
| | | | | | | | |
| | | | | | | | |
| | | | | | | | |
| | | | | | | | |
| | | | | | | | |
| | | | | | | | |
| | | | | | | | |
| | | | | | | | |
| | | | | | | | |
| | | | | | | | |
| | | | | | | | |
| | | | | | | | |
| | | | | | | | |
| | | | | | | | |
| | | | | | | | |
| | | | | | | | |
| | | | | | | | |

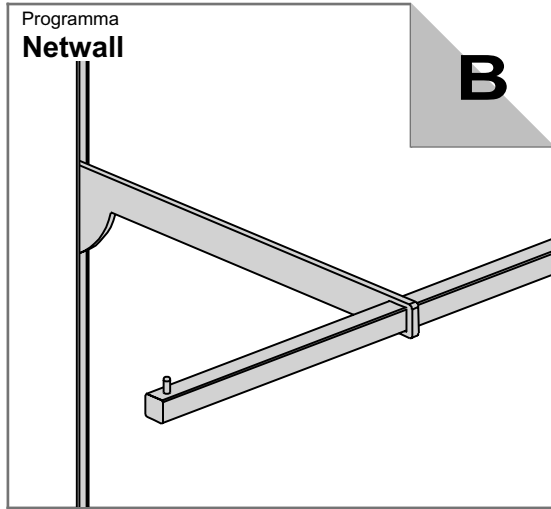

Schema di utilizzo

Diagram about use

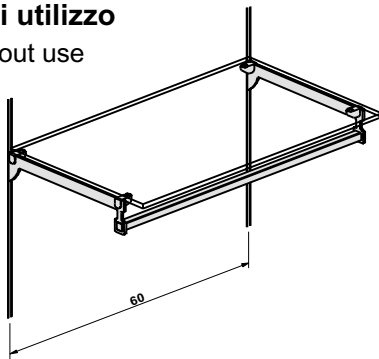

La lunghezza dei ripiani in vetro e dei tubi appenderia è stata realizzata considerando il passo tra i profili a 60 cm.

Lenght about glass tops and hanging tubes has been realized considering pitch between profiles at 60 cms.

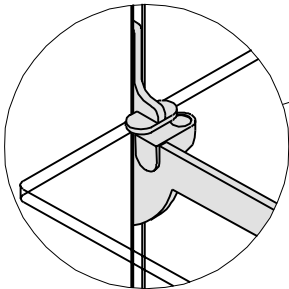

L'antiribaltamento può essere applicato solo su vetri di spessore 8 mm.
No-upsetting element can be applied only on glass with a thickness of 8 mm.

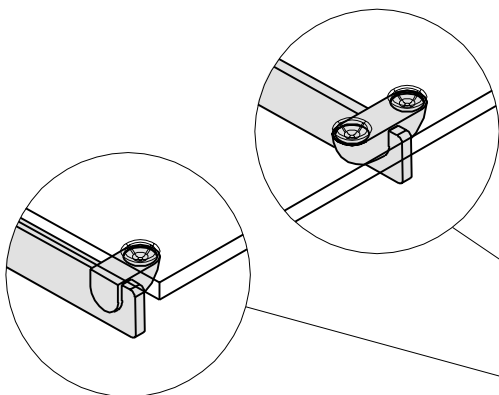

Le mensole dei ripiani non sono provviste di cavallotti. Questi devono essere ordinati separatamente, in base alle esigenze, scegliendo tra il cavallotto terminale e quello centrale.
Brackets about tops are without u-bolts. These had to be ordered separately choosing between terminal and central.

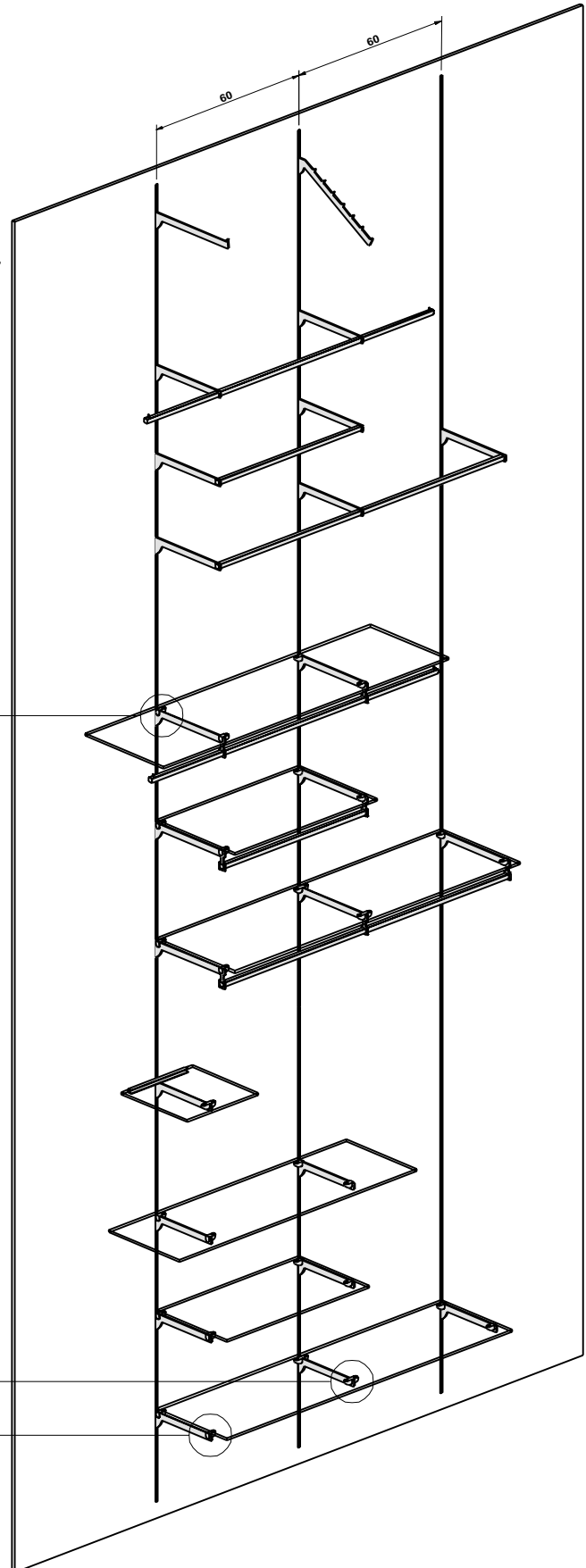

Accessori per cremagliera

Accessories for rack

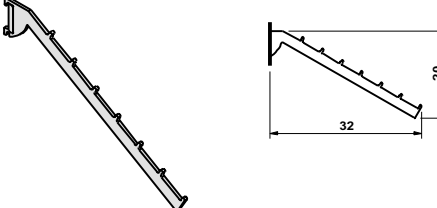
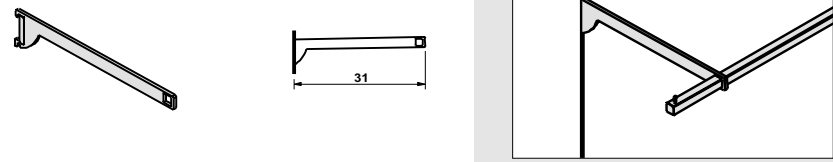
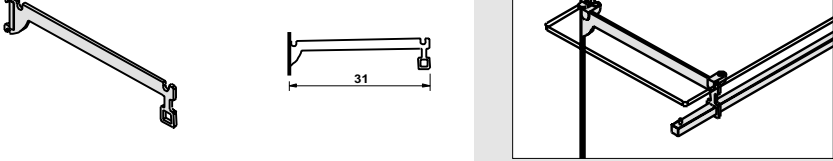
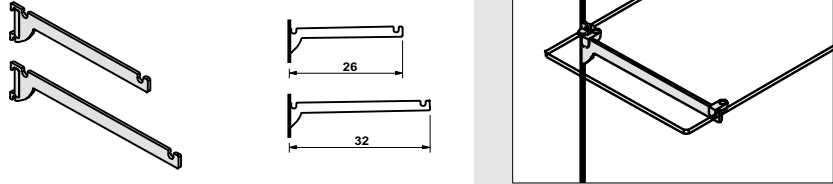
| Programma Netwall | Specifiche Details | P | H | L | Codice Code | c1 | c2 | c3 | c4 |
|--|--|----|----|---|----------------|----|----|----|----|
| Gancera frontale diritta Frontal hook rack |  | 32 | | | 1G58 001 | | ☒ | | |
| Gancera frontale inclinata Inclined frontal hook rack |  | 32 | 20 | | 1G58 002 | | ☒ | | |
| Supporto per tubo appenderia Bearing for hanging tube |  | 31 | | | 1G58 003 | | ☒ | | |
| Mensola con supporto per tubo appenderia Bracket with bearing for hanging tube |  | 31 | | | 1G58 004 | | ☒ | | |
| Mensole per piani vetro o legno Brackets for glass or wooden tops |  | 26 | | | 1G58 005 | | ☒ | | |
| | | | 32 | | 1G58 006 | | ☒ | | |

| |
|-----------------------------|
| Programma Netwall |
|-----------------------------|

| |
|------------------------------|
| Specifiche Details |
|------------------------------|

| P | H | L | Codice Code | c1 | c2 | c3 | c4 |
|---|---|---|----------------|----|----|----|----|
|---|---|---|----------------|----|----|----|----|

Tubi appenderia
Hanging tubes

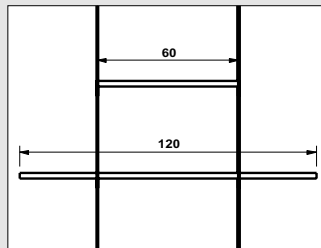
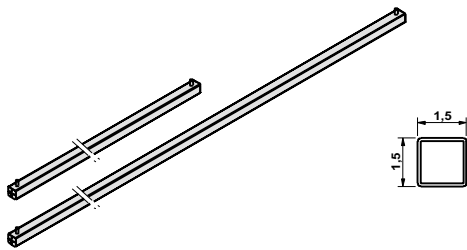

| | | | | | | | |
|-----|-----|-----|-----------------|--|---|--|--|
| 1,5 | 1,5 | 60 | 1G51 001 | | ☒ | | |
| 1,5 | 1,5 | 120 | 1G51 002 | | ☒ | | |

Ripiani in vetro
Glass tops

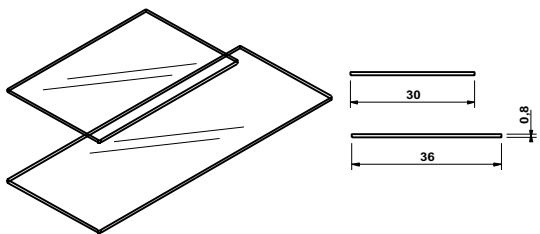

Vetro trasparente
Transparent glass

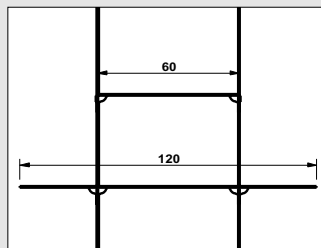

| | | | | | | | |
|----|-----|-----|-----------------|--|--|--|--|
| 30 | 0,8 | 60 | 1G53 001 | | | | |
| 30 | 0,8 | 120 | 1G53 002 | | | | |

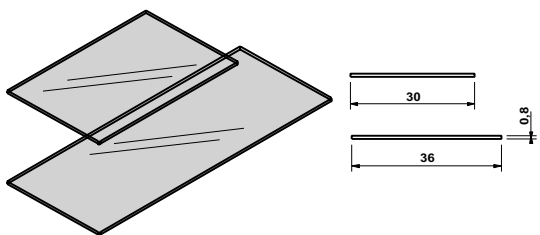

Vetro acidato
Glazed glass

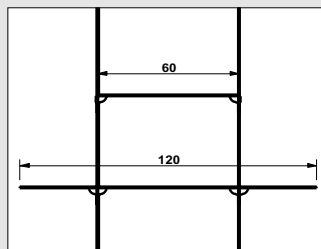

| | | | | | | | |
|----|-----|-----|-----------------|--|--|--|---|
| 30 | 0,8 | 60 | 1G53 006 | | | | 2 |
| 30 | 0,8 | 120 | 1G53 007 | | | | 2 |
| 36 | 0,8 | 60 | 1G53 003 | | | | |
| 36 | 0,8 | 120 | 1G53 004 | | | | |
| 36 | 0,8 | 60 | 1G53 008 | | | | 2 |
| 36 | 0,8 | 120 | 1G53 009 | | | | 2 |

Cavallotti ed antiribaltamento
U-bolts and no-upsetting element

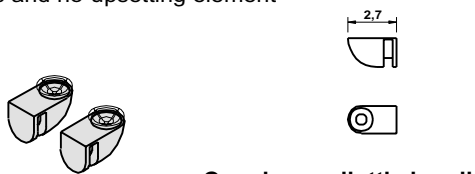

Coppia cavallotti singoli
Couple of single u-bolts

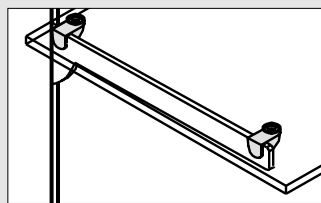

| | | | | | | | |
|--|--|--|-----------------|--|---|--|--|
| | | | 1G58 007 | | ☒ | | |
|--|--|--|-----------------|--|---|--|--|

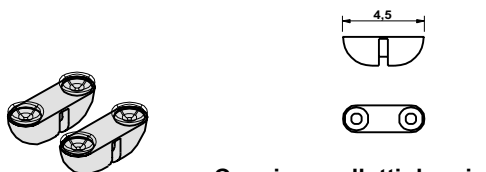

Coppia cavallotti doppi
Couple of double u-bolts

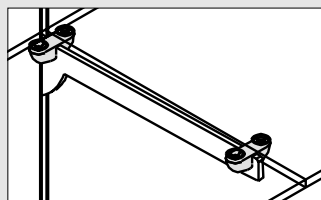

| | | | | | | | |
|--|--|--|-----------------|--|---|--|--|
| | | | 1G58 008 | | ☒ | | |
|--|--|--|-----------------|--|---|--|--|

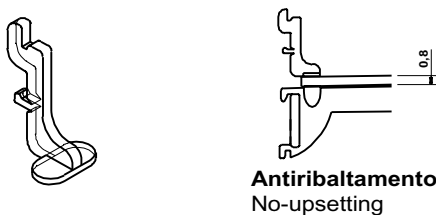

Antiribaltamento
No-upsetting

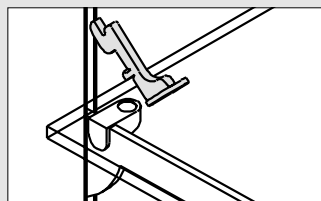

| | | | | | | | |
|--|--|--|-----------------|--|--|--|---|
| | | | 1G58 009 | | | | ▽ |
|--|--|--|-----------------|--|--|--|---|

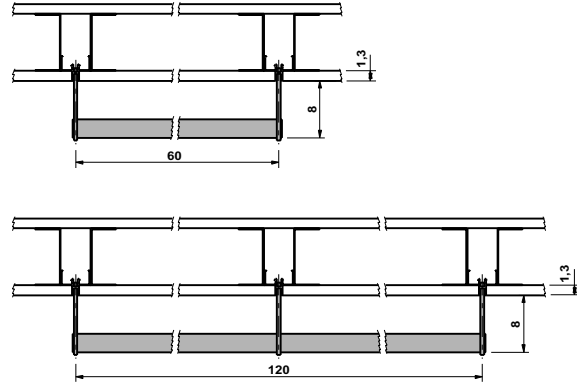
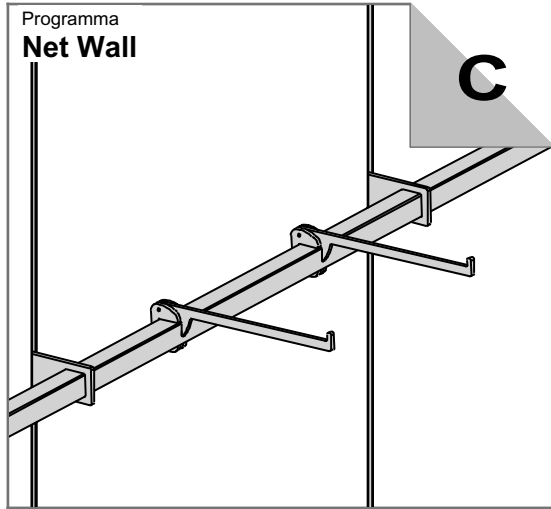

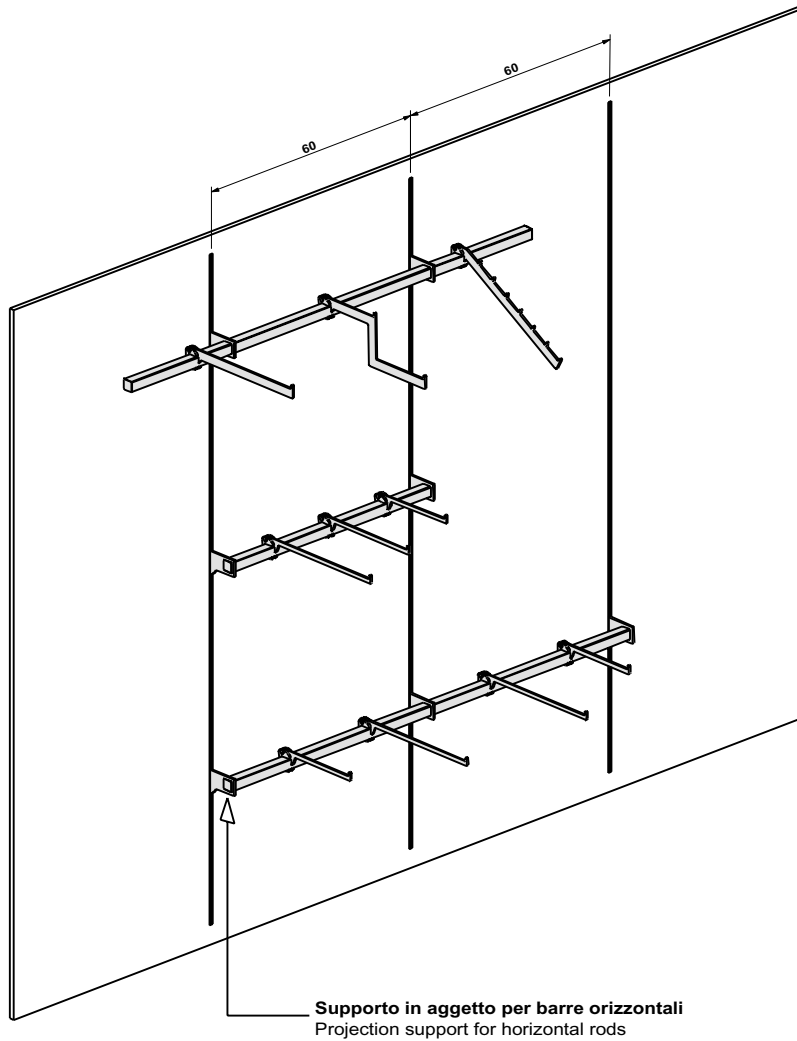

Schema di utilizzo

Diagram about use

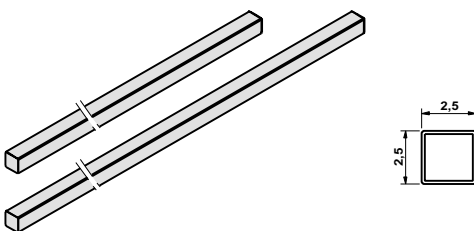
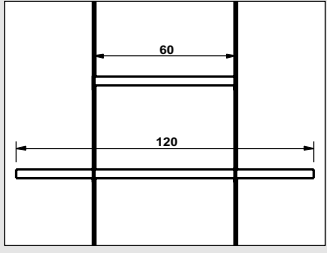

Accessori per barra orizzontale

Accessories for horizontal rod

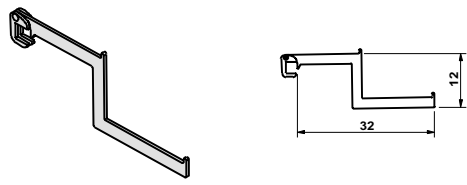
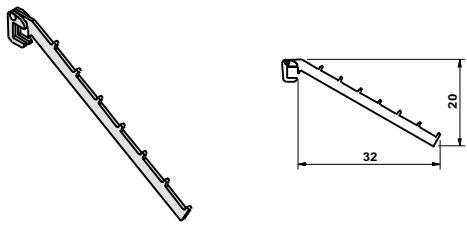
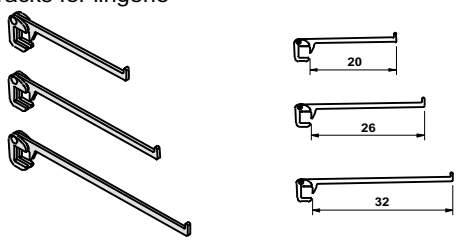
| Programma Netwall | | Specifiche Details | | | P | H | L | Codice Code | c1 | c2 | c3 | c4 | |
|--|--|-----------------------|--|--|---|---|-----|-----------------|-----------------|-----------------|----|----|--|
| Supporto in aggetto per barre orizzontali Projection support for horizontal rods | | | | | | | | | | | | | |
|  | | | | | | | 8 | 1G58 011 | | ☒ | | | |
| Barre orizzontali Horizontal rods | | | | | | | | | | | | | |
|  | | | | | | | 2,5 | 2,5 | 60 | 1G51 003 | | ☒ | |
| | | | | | | | 2,5 | 2,5 | 120 | 1G51 004 | | ☒ | |
|  | | | | | | | | | | | | | |
| Gancera snodata diritta Jointed hook-rack | | | | | | | | | | | | | |
|  | | | | | | | 32 | 1A58 125 | | ☒ | | | |
| Gancera snodata a 2 livelli Two levels jointed hook-rack | | | | | | | | | | | | | |
|  | | | | | | | 32 | 12 | 1A58 126 | | ☒ | | |
| Gancera snodata inclinata Inclined jointed hook-rack | | | | | | | | | | | | | |
|  | | | | | | | 32 | 20 | 1A58 127 | | ☒ | | |
| Gancere porta-lingerie Hook-racks for lingerie | | | | | | | | | | | | | |
|  | | | | | | | 20 | 1G58 012 | | ☒ | | | |
| | | | | | | | 26 | 1G58 013 | | ☒ | | | |
| | | | | | | | 32 | 1G58 014 | | ☒ | | | |

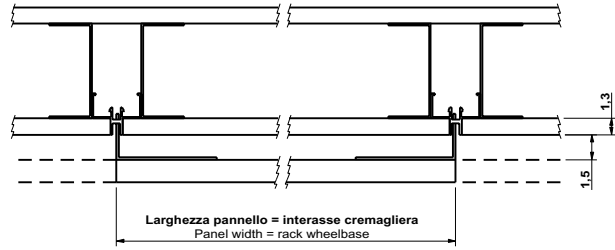
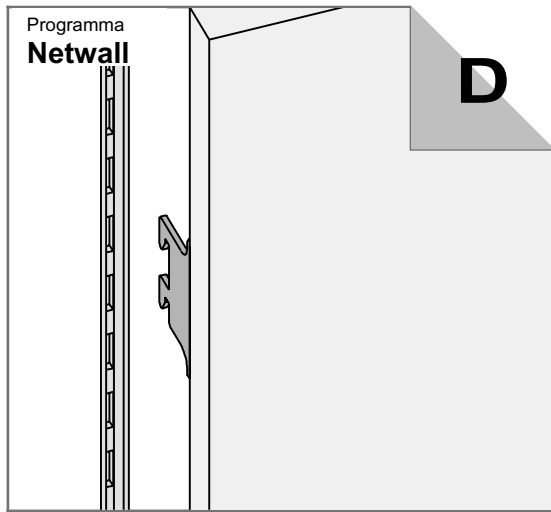

Schema di utilizzo

Diagram about use

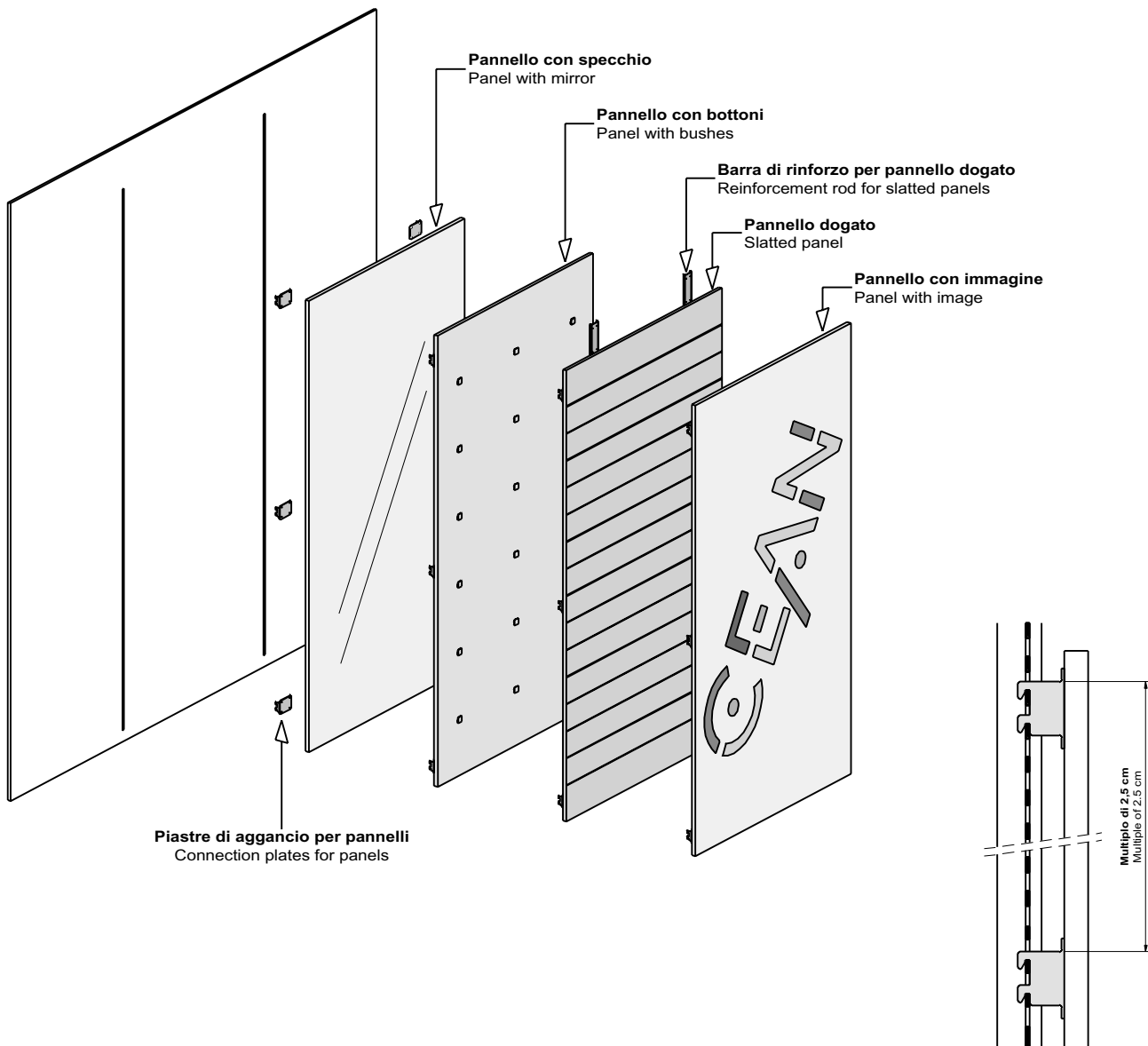

Posizionare gli agganci per pannelli a distanze multiple di 2,5 cm.
Put connections for panels at distances multiple of 2.5 cms.

Piastre di aggancio per pannelli

Connection plate for panels

Programma
Netwall

Specifiche
Details

P

H

L

Codice
Code

c1

c2

c3

c4

Coppia piastre di aggancio per pannelli
Connection plates for panels

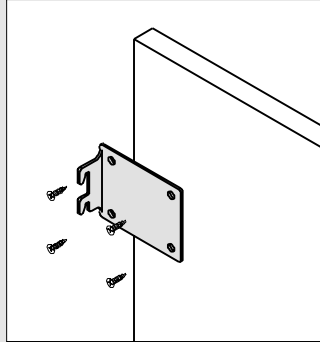
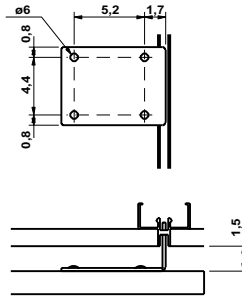
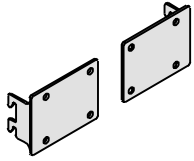

1G58 016 

Coppia barre di rinforzo per pannelli dogati
Pair of reinforcement rod for slatted panels

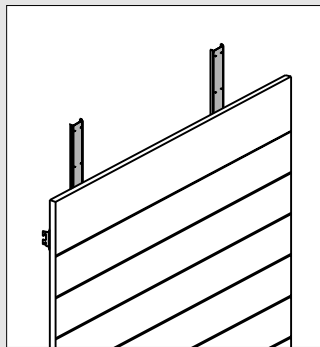
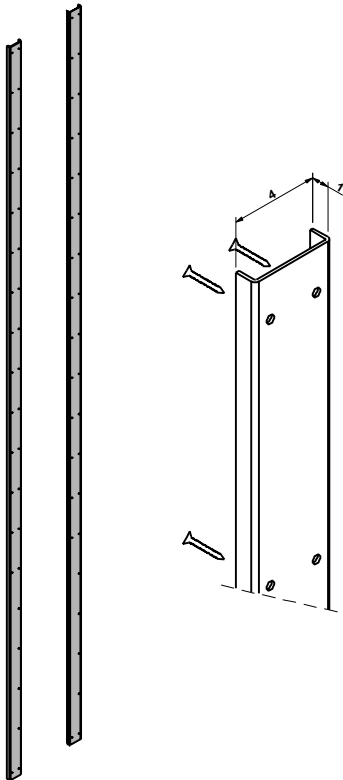

1 220 4 1G58 019 

CONDIZIONI GENERALI DI VENDITA

1) PREZZI

I prezzi si intendono netti di IVA. Gli stessi potranno essere modificati a seguito di variazioni di mano d'opera e/o materie prime. Tali modifiche verranno notificate per iscritto.

2) CONSEGNA

Franco stabilimento in Fano. La merce viaggia sempre a rischio e pericolo del committente.

3) TRASPORTO

In mancanza di istruzioni precise la consegna sarà effettuata tramite il vettore che la CEAN COMPANY SPA riterrà più opportuno e questo non potrà dar luogo ad alcun reclamo.

La CEAN COMPANY SPA non si assume nessuna responsabilità per danni, furti o avarie subiti durante il trasporto. In questi casi il committente dovrà rivalersi esclusivamente al trasportatore.

4) IMBALLAGGI

I materiali sono imballati a seconda della loro conformazione e fragilità in cartone, plastica o legno senza aggiunta di prezzo. Per imballi particolari necessari in caso di spedizioni tramite corrieri speciali, sarà addebitato il prezzo di costo. Eventuali danni agli imballaggi dovranno essere immediatamente contestati dal cliente al trasportatore con una annotazione sulla bolla di consegna. In assenza di contestazione scritta la merce si intenderà ricevuta in perfette condizioni di imballo.

5) RECLAMI

Il cliente dovrà controllare scrupolosamente la merce al momento della presa in consegna e le eventuali contestazioni per difetti o mancanze di materiali dovranno essere fatte esclusivamente per iscritto entro 8 giorni dalla data di ricevimento della merce. Dopo tale termine la merce si intende accettata nello stato nella quale è stata consegnata.

6) RESTITUZIONE DI MATERIALI

La restituzione di materiali non autorizzati precedentemente per iscritto da un nostro responsabile non sono accettati e comunque i resi autorizzati dovranno essere liberi da ogni spesa franco nostro magazzino e sarà accreditato al prezzo di vendita scontato del 10%.

7) PAGAMENTI

Le condizioni di pagamento concordate dovranno essere scrupolosamente rispettate e gli eventuali ritardi anche di qualche giorno comporteranno automaticamente un addebito di interessi al tasso corrente più le eventuali spese reclamate dagli Istituti di credito per titoli insoluti.

Le eventuali contestazioni concernenti partite specifiche di merci non potranno in alcun modo e per alcuna ragione sospendere i pagamenti di altre partite non contestate.

8) FORO COMPETENTE

Qualsiasi controversia sarà di esclusiva competenza del Tribunale di Fano o di Pesaro.

N.B. La CEAN COMPANY SPA si riserva la possibilità di apportare modifiche strutturali, estetiche, cromatiche o di sopprimere alcuni articoli senza obbligo di preavviso ai clienti.

N.B. La riproduzione totale o parziale delle descrizioni e/o delle illustrazioni del presente catalogo è assolutamente PROIBITA.

GENERAL TERMS OF SALE

1) PRICES

The prices shown do not include VAT. These may be amended following changes in labour costs and/or the price of raw materials. Such amendments will be notified in writing.

2) DELIVERY

Ex Fano works. Goods always travel at the buyer's risk.

3) TRANSPORT

In the absence of precise instructions, delivery will be made through a carrier appointed by CEAN COMPANY SPA and this shall not represent grounds for any claims whatsoever.

CEAN COMPANY SPA disclaims all liability for damage, theft or faults occurring during transport. Only the carrier shall be liable towards the buyer in such cases.

4) PACKAGING

Goods are packed according to their shape and degree of fragility in cardboard, plastic or wood at no extra charge. In the case of special packagings required in the event of dispatch by special courier service, the cost price will be charged. The customer shall immediately notify the carrier of any damage to packagings, and a note shall be made thereof on the delivery note. In the absence of any written claim, goods shall be considered as received in perfect packaging condition.

5) CLAIMS

The customer must carefully check goods upon receipt and any claims concerning faults or missing goods shall be made exclusively in writing within 8 days from the date of receipt. After this time, the goods shall be considered as accepted in the condition in which they were delivered.

6) RETURN OF GOODS

Goods shall not be returned without prior written authorisation from our company. All authorised returned goods shall be sent free of all charges to our warehouse and shall be credited at the sales price less 10%.

7) PAYMENT

The agreed payment conditions shall be scrupulously complied with and any, even minor, delays shall automatically result in the charging of interest at current rates plus any bank costs for bills outstanding. Any claims concerning specific shipments of goods shall under no circumstances and for no reason constitute grounds for suspending the payment of other shipments for which no claims have been lodged.

8) JURISDICTION

Any disputes shall fall within the exclusive jurisdiction of the Courts of Fano or Pesaro.

Note : CEAN COMPANY SPA reserves the right to make structural, aesthetic and colour changes or to withdraw its articles from the market without prior notification.

Note : Total or partial reproduction of the descriptions and/or illustrations in this catalogue is absolutely FORBIDDEN.



CEAN COMPANY S.P.A. VIA DAVIDE ALBERTARIO 3/A 61030 BELLOCCHI DI FANO (PU) ITALY
TEL. +39 0721 855 046, FAX +39 0721 859 182 INFO@CEANCOMPANY.IT

